



1. DESCRIPTION

Viking FSX-A Deluge Systems utilize a Viking Model FSX-A Deluge Valve to control the water supply to system piping equipped with open sprinklers and/or spray nozzles.

The system piping remains empty until the deluge valve is activated by operation of the release system. Deluge systems are commonly used where it is desirable to simultaneously spray water from all open sprinklers and/or nozzles on the system when it operates.

Deluge systems with electric release require an electric solenoid valve controlled by an approved system release control panel with compatible detection system.

Deluge systems with hydraulic release uses a pilot line that is directly connected to the control chamber of the deluge valve. The system pressure of the water supply is permanently applied to the pilot line. When a pilot sprinkler is activated, the pilot line pressure and deluge control chamber pressure drops which opens the valve.

In fire conditions, when the detection system operates, the system release control panel energizes solenoid valve open, causing the deluge valve to open and allowing water to enter the system piping. Water will flow from any open sprinklers and/or spray nozzles on the system.

In case of a power failure, the Pilot Operated Relief Valve ensures that the system continues to operate.

The FSX-A Deluge System is UL Listed and FM Approved.

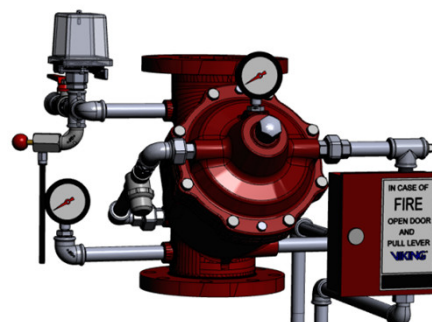

2. VALVE TECHNICAL DATA

Valve Type	Hydraulically operated quick opening differential type
Nominal Diameter	2" / DN50 , 3" / DN80 , 4" / DN100 , 6" / DN150 , 8" / DN200
Working Pressure	250psi / 17.2 bar (UL) 232 psi / 16.0 bar (FM)
Flange Connection	ANSI B16.5 Class 150 / DIN ISO in accordance with DIN EN 1092
Grooved Connection	Metric, AWWA C606 Standard
Installation Position	Vertical
Medium	Fresh Water / Foam Water Mixture
Operating Temperature	4°C / 39°F - 60°C / 140°F

Valve parts

- | | |
|---------------------|-------------------------|
| 1. Housing | 14. Pressure spring |
| 2. Valve seat | 15. Guide plug |
| 3. Guide bearing | 16. O-ring |
| 4. Cover | 17. O-ring |
| 5. Guide bush | 18. O-ring |
| 6. Valve rod | 19. Hexagon bolt |
| 7. Valve disc | 20. Hexagon bolt |
| 8. Gasket | 21. Nameplate* |
| 9. Holding disc | 22. Grooved drive stud* |
| 10. O-ring | 23. Threaded plug |
| 11. Hexagon Nut | |
| 12. Supporting Disc | |
| 13. Diaphragm | |

* Not visible on illustration

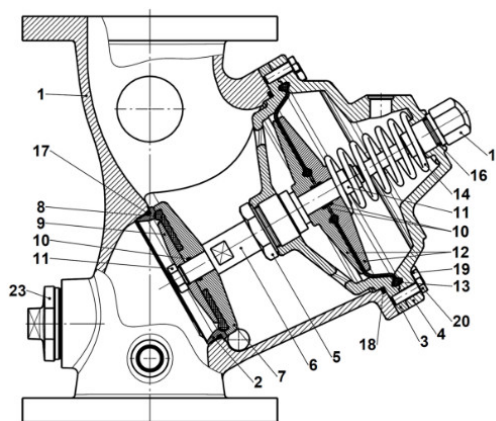



PRODUCT SHEET

FSX-A Deluge
Electric, Hydraulic Release



The Viking Corporation (Far East) Pte. Ltd. | 69 Tuas View Square Westlink Techpark, Singapore 637621

ASIA PACIFIC ONLY

2. VALVE TECHNICAL INFORMATION

Valve Materials

Valve Body	Ductile Iron
Valve Seat	Brass
Piston Rod	Stainless Steel
Valve Disc	Brass
Diaphragm	NBR fire reinforced
Gaskets NBR	4°C / 39°F - 60°C / 140°F
Finish	RAL 300 Primer & Clear Coat

Valve Pressures & Flowrates

Pressure		Flow Velocity	
Bar	PSI	m/sec	ft/sec
2.0	29.0	5	16.4
2.5	36.0	7	23.0
3.0	43.5	8	26.2
3.8	55.0	10	32.8

Valve Flowrate & Velocity

Valve Size		DIN EN 10220	V		Q	
Inch	DN	mm	m/s	ft/s	ltr/min	gpm
2	50	60.3 x 2.6	10	32.8	1,340	354
3	80	88.9 x 2.9	10	32.8	3,195	844
4	100	114.3 x 3.2	10	32.8	5,427	1,434
6	150	168.3 x 4.0	10	32.80	12,050	3,184
8	200	219.1 x 4.5	10	32.8	20,742	5,480

Valve Size		Schedule 40	Equivalent Length		Q	
Inch	DN	mm	m/s	ft/s	ltr/min	gpm
2	50	60.3 x 3.91	10	32.8	1,240	328
3	80	88.9 x 5.49	10	32.8	2,802	740
4	100	114.3 x 6.02	10	32.8	4,869	1,286
6	150	168.3 x 7.11	10	32.80	11,128	2,940
8	200	219.1 x 8.18	10	32.8	19,340	5,110



2. VALVE TECHNICAL INFORMATION

Valve Friction Loss

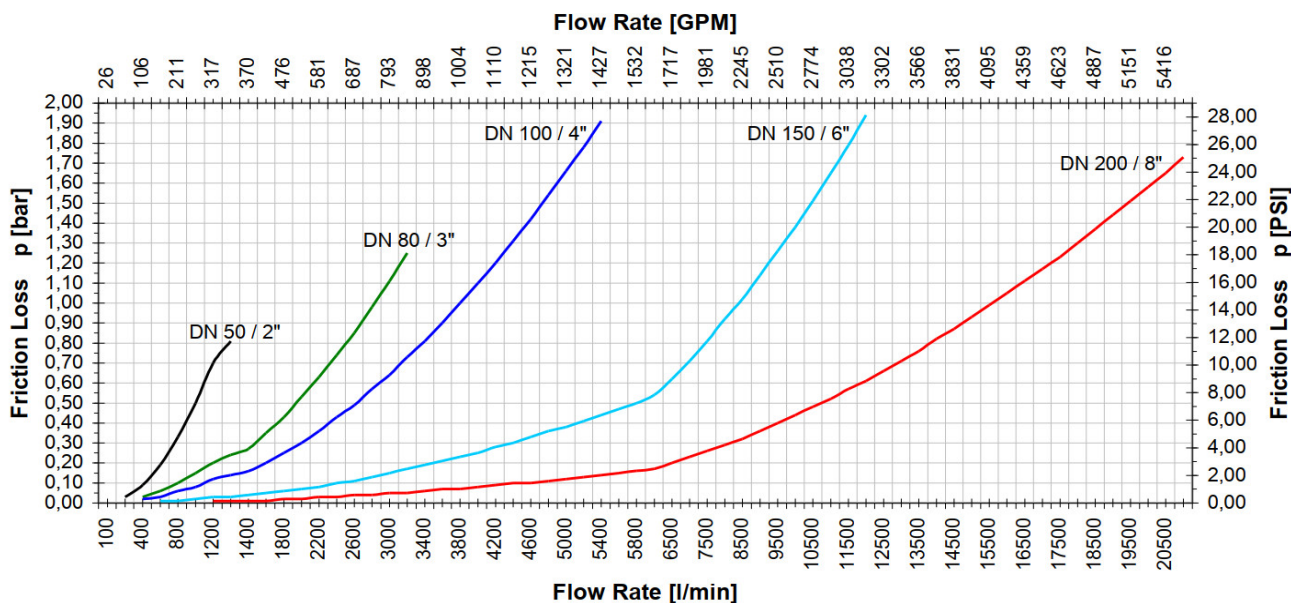

Pipe Equivalent Length

Valve Size		DIN EN 10220	Equivalent Length		Δp		Q	
Inch	DN	mm	m	ft	bar	psi	ltr/min	gpm
2	50	60.3 x 2.6	4.65	15.26	0.18	2.63	594	157
3	80	88.9 x 2.9	10.63	34.87	0.24	3.54	1,310	346
4	100	114.3 x 3.2	21.96	72.05	0.38	5.44	2,256	596
6	150	168.3 x 4.0	34.96	114.70	0.40	5.85	5,114	1,351
8	200	219.1 x 4.5	41.38	135.76	0.35	4.99	8,854	2,339

Valve Size		Schedule 40	Equivalent Length		Δp		Q	
Inch	DN	mm	m	ft	bar	psi	ltr/min	gpm
2	50	60.3 x 3.91	3.67	12.04	0.18	2.63	594	157
3	80	88.9 x 5.49	7.77	25.49	0.24	3.54	1,310	346
4	100	114.3 x 6.02	16.91	55.48	0.38	5.44	2,256	596
6	150	168.3 x 7.11	28.83	94.59	0.40	5.85	5,114	1,351
8	200	219.1 x 8.18	34.78	114.11	0.35	4.99	8,854	2,339



3. SYSTEM COMPONENTS

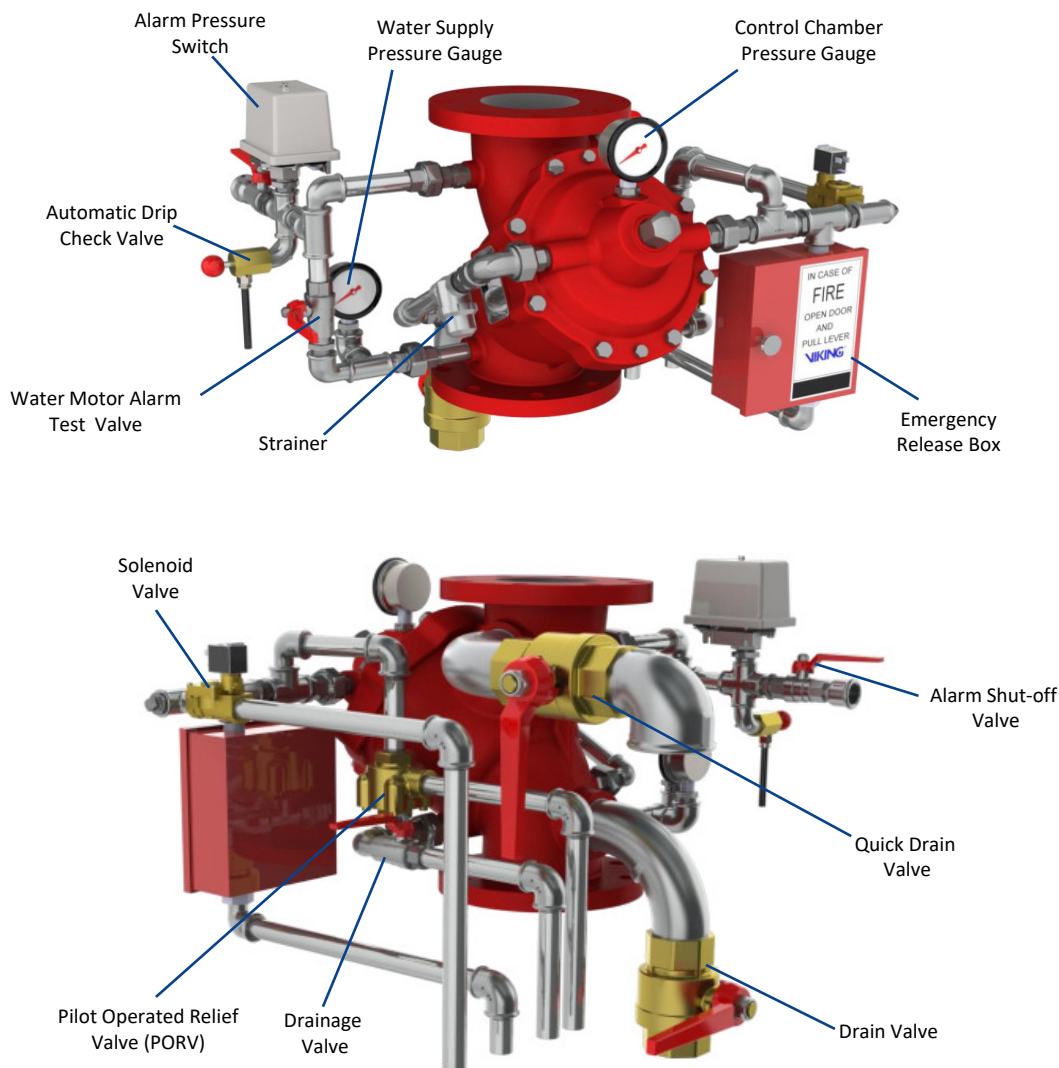

Item	Function
Alarm Pressure Switch	Enables monitoring through the fire detection control panel if the deluge valve has triggered.
Automatic Drip Check Valve	Automatic draining of the alarm line.
Control Chamber Pressure Gauge	Displays control chamber water pressure. Pressure should be greater or equal to water supply pressure.
Drain Valve	Used to test water supply upstream of the deluge valve according to NFPA regulations. Used to drain water from deluge valve.
Emergency Release Box	To enable the system to be triggered manually.
PORV (Pressure Operated Relief Valve)	Prevents accidental closing of the deluge valve in event of a fire and in case of an accidental interruption of power supply to the solenoid valve.
System Air Pressure Gauge	Displays the air pressure in the system.
Solenoid Valve	Is activated by the fire detection control panel and activates the system.
Strainer	Filters the water supplied to the release devices.
Water Motor Alarm Test Valve	Used to test the water motor alarm and alarm pressure switch without flooding the system.
Water Motor Isolation Valve	Used to shut off the water motor alarm.
Water Supply Pressure Gauge	Displays the pressure of the water supply
Water Motor Alarm Test Valve	Used to test the water motor alarm and alarm pressure switch without flooding the system.
Water Motor Isolation Valve	Used to shut off the water motor alarm.

Note: Diagram is based on electric release. Hydraulic release will not require the use of the solenoid valve.



4. DIMENSIONS

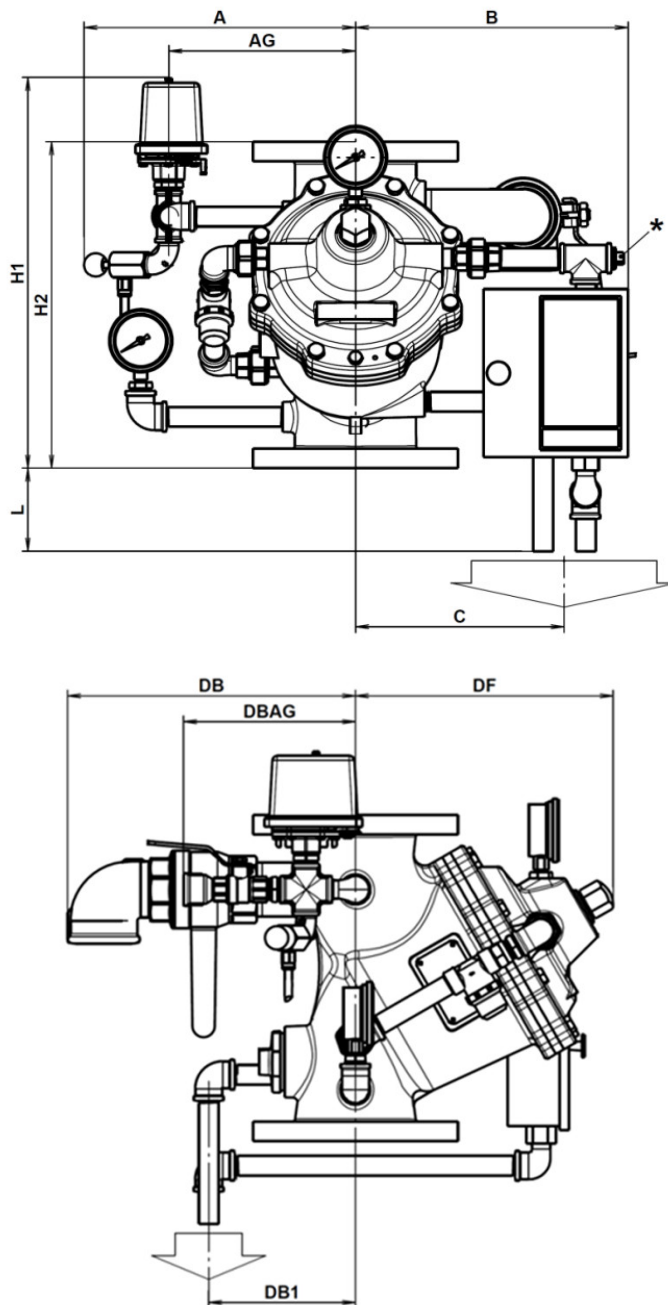

Valve Size		Dimensions (mm)										
Inch	DN	A	AG	B	C	L	H1	H2	DF	DB	DBAG	DB1
2	50	310	220	220	20	150	400	280	210	210	190	140
3	80	320	22	270	225	120	410	310	250	245	190	150
4	100	290	200	280	235	90	420	350	280	330	190	160
6	150	320	22	315	260	15	500	480	335	325	190	170
8	200	355	250	415	305	10	<H2	600	450	325	190	180

Dimensions in mm



PRODUCT SHEET

FSX-A Deluge Electric, Hydraulic Release



The Viking Corporation (Far East) Pte. Ltd. | 69 Tuas View Square Westlink Techpark, Singapore 637621

ASIA PACIFIC ONLY

5. ORDERING INFORMATION

Part Number	Description	Deluge Hydraulic Release					Deluge Electric Release					
		2" DN50	3" DN80	4" DN100	6" DN150	8" DN200	2" DN50	3" DN80	4" DN100	6" DN150	8" DN200	
DELUGE VALVE (CHOOSE FLANGE OR GROOVED TYPE)												
Flange Connection	VKD050ULANSI	2" Deluge Valve Model FSX-A ANSI B16.5 Class 150 UL/FM	X					X				
	VKD080ULANSI	3" Deluge Valve Model FSX-A ANSI B16.5 Class 150 UL/FM		X					X			
	VKD100ULANSI	4" Deluge Valve Model FSX-A ANSI B16.5 Class 150 UL/FM			X					X		
	VKD150ULANSI	6" Deluge Valve Model FSX-A ANSI B16.5 Class 150 UL/FM				X					X	
	VKD200ULANSI	8" Deluge Valve Model FSX-A ANSI B16.5 Class 150 UL/FM					X					X
OR												
Grooved Connection	VKD050GG060MM	2" Deluge Valve Model FSX-A Grooved 60mm UL/FM	X					X				
	VKD080GG089MM	3" Deluge Valve Model FSX-A Grooved 89mm UL/FM		X					X			
	VKD100GG114MM	4" Deluge Valve Model FSX-A Grooved 114mm UL/FM			X					X		
	VKD150GG165MM	6" Deluge Valve Model FSX-A Grooved 165mm UL/FM									X	
	OR	OR				X						X
	VKD150GG168MM	6" Deluge Valve Model FSX-A Grooved 168mm UL/FM										X
	VKD200GG219MM	8" Deluge Valve Model FSX-A Grooved 219mm UL/FM					X					
HYDRAULIC TRIM ASSEMBLY (includes PORV, fast drainage set, alarm test set, emergency manual release, pressure gauges)												
VKT050UL	2" Hydraulic Actuation Trim Set	X						X				
VKT080UL	3" Hydraulic Actuation Trim Set		X						X			
VKT100UL	4" Hydraulic Actuation Trim Set			X						X		
VKT150UL	6" Hydraulic Actuation Trim Set				X						X	
VKT200UL	8" Hydraulic Actuation Trim Set					X						X
ELECTRICAL TRIM ASSEMBLY (excludes solenoid valve)												
VKSV050TA	2" Electrical Actuation Trim Set							X				
VKSV080TA	3" Electrical Actuation Trim Set								X			
VKSV100TA	4" Electrical Actuation Trim Set									X		
VKSV150TA	6" Electrical Actuation Trim Set										X	
VKSV200TA	8" Electrical Actuation Trim Set											X
TEST CONNECTION												
VKTCS050	2" Test Connection Set	X						X				
VKTCS080	3" Test Connection Set		X						X			
VKTCS100-200	4", 6", 8" Test Connection Set			X	X	X				X	X	X
OTHERS												
1340101 / 1340103	PS101A / PS10-1 Pressure Switch (Single Contact), UL/FM	X	X	X	X	X	X	X	X	X	X	X
912434	Solenoid Valve NC 24V including Plug							X	X	X	X	X
7862	Water Motor Alarm Gong	X	X	X	X	X	X	X	X	X	X	X
SPARE PARTS												
VKATS050-200	2", 3", 4", 6", 8" Alarm Test Set											
16970	Pressure Operated Relief Valve (PORV) D3											
01553C	Emergency Manual Release Box Model C1											
911692	Pressure Gauge 300PSI-1 / 4BSP- Type 711											



6. DELUGE VALVE ASSEMBLY

6.1 Control chamber pressure gauge

DN50 / 2" to DN200 / 8"	
Item	Description
1	Pressure gauge
2	Red. -nipple N4- 1/2"x1/4-Zn-A

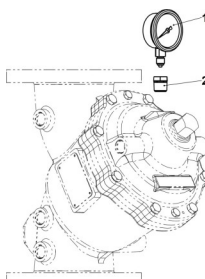

6.2 Bypass Connection

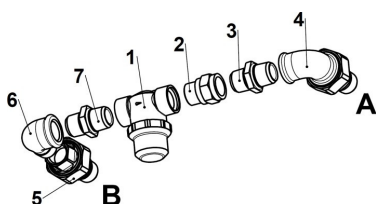

DN50 / 2"	
Item	Description
1	Strainer 1/2"
2	Check valve G1/2"-I/A
3*	Orifice 1/2" 3.5mm
4	Union UA12-1/2"-Zn-A
5	Union U12-1/2"-Zn-A
6	Elbow A4-1/2"-Zn-A
7*	Hex. nipple N8-1/2"-Zn-A

* Do NOT mix up Pos. 3 with Pos. 7

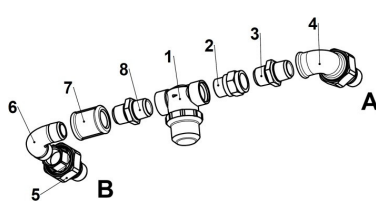

DN80 / 3"	
Item	Description
1	Strainer 1/2"
2	Check valve G1/2"-I/A
3*	Orifice 1/2" 3.5mm
4	Union UA12-1/2"-Zn-A
5	Union U12-1/2"-Zn-A
6	Elbow G8-1/2"-Zn-A
7	Socket M2-1/2"-Zn-A
8*	Hex. nipple N8-1/2"-Zn-A

* Do NOT mix up Pos. 3 with Pos. 8

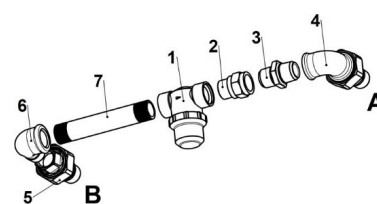

DN100 / 4"	
Item	Description
1	Strainer 1/2"
2	Check valve G1/2"-I/A
3	Orifice 1/2" 3.5mm
4	Union UA12-1/2"-Zn-A
5	Union U12-1/2"-Zn-A
6	Elbow A4-1/2"-Zn-A
7	Pipe nipple 1/2"-Zn

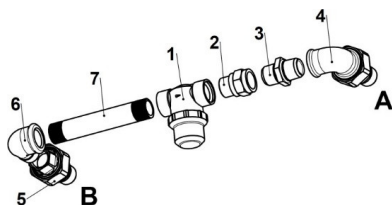

DN100 / 4"	
Item	Description
1	Strainer 1/2"
2	Check valve G1/2"-I/A
3	Orifice 1/2" 3.5mm
4	Union UA12-1/2"-Zn-A
5	Union U12-1/2"-Zn-A
6	Elbow A4-1/2"-Zn-A
7	Pipe nipple 1/2"-Zn

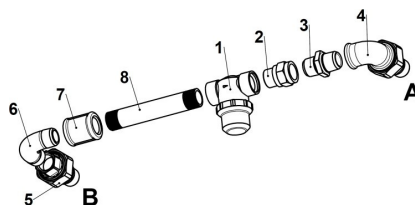

DN150 / 6"	
Item	Description
1	Strainer 1/2"
2	Check valve G1/2"-I/A
3	Orifice 1/2" 3.5mm
4	Union UA12-1/2"-Zn-A
5	Union U12-1/2"-Zn-A
6	Elbow A4-1/2"-Zn-A
7	Socket 1/2"-Zn-A
8	Pipe nipple 1/2"-Zn

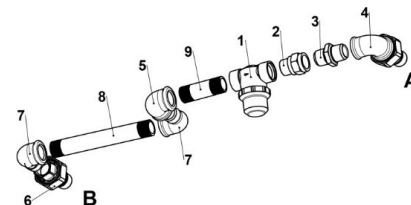

DN200 / 8"	
Item	Description
1	Strainer 1/2"
2	Check valve G1/2"-I/A
3	Orifice 1/2" 3.5mm
4	Union UA12-1/2"-Zn-A
5	Union U12-1/2"-Zn-A
6	Elbow A4-1/2"-Zn-A
7	Socket 1/2"-Zn-A
8	Pipe nipple 1/2"-Zn
9	Pipe nipple 1/2"-Zn

6. DELUGE VALVE ASSEMBLY

6.3 Water Supply pressure gauge

DN50 / 2" to DN200 / 8"	
Item	Description
1*	Pipe nipple 1/2"-Zn
2	Elbow A1-1/2"-Zn-A
3	Red.- nipple N4-1/2"x1/4"-ZN-A
4	Pressure gauge

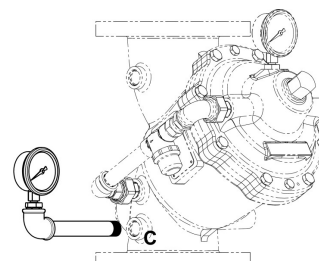
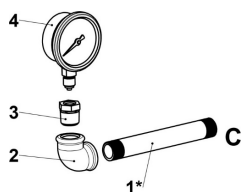

*The pipe nipple is not required if the alarm test equipment is installed.

6.4 Alarm Line

DN50 / 2" to DN200 / 8"	
Item	Description
1	Pipe nipple 1/2"-Zn
2	Elbow A4-1/2"-Zn-A
3	Cross union A1-1/2"-Zn-A
4*	Hex. nipple N8-1/2"-Zn-A
5	Ball valve 1/2"
6	Socket N4- -3/4"x1/2"-Zn-A
7*	Alarm pressure switch
8	Elbow 94-1/2"-Zn
9	Drain valve

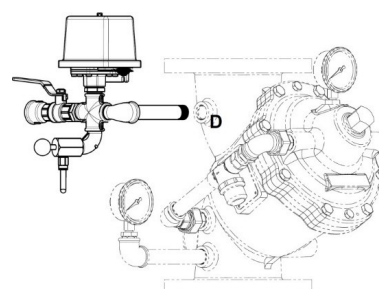
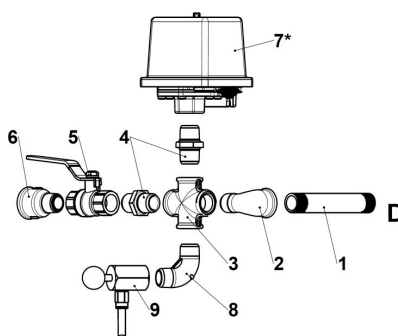

*If a pressure switch (Pos. 7) with an outer thread is used, the Hex. nipple located underneath (Pos. 4) is not required.

6.5 Manual Release

DN50 / 2" to DN200 / 8"	
Item	Description
1	Union U12-1/2"-Zn-A
2	Pipe nipple 1/2"-Zn
3	Tee A1-1/2"-Zn-A
4*	Plug T9-1/2"-Zn-A
5	Emergency release box
6	Elbow A4-1/2"-Zn-A
7*	Pipe nipple 1/2"
8	Elbow A1-1/2"-Zn-A
9	Pipe nipple 1/2"

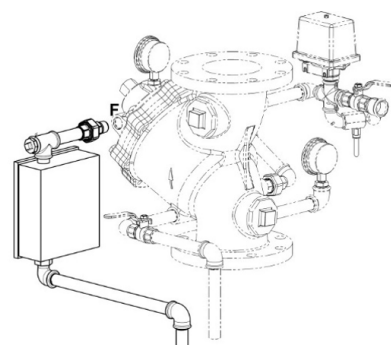
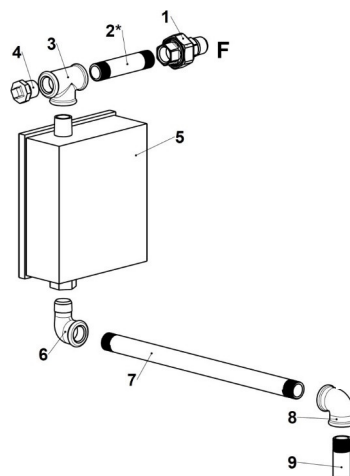

6. DELUGE VALVE ASSEMBLY

6.6 Pressure operated relief valves (PORV)

DN50 / 2" to DN200 / 8"	
Item	Description
1	Hex. nipple N8-1/2"-Zn-A
2	Tee 133-1/2"-Zn
3	Elbow A4-1/2"-Zn-A
4	Pipe nipple 1/2"
5	Elbow A1-1/2"-Zn-A
6	Pipe nipple 1/2"
7	Diaphragm valve PORV D3
8	Tee 135-1/2"-Zn
9	Union U12-1/2"-Zn-A
10	Pipe nipple 1/2"
11	Pipe nipple 1/2"

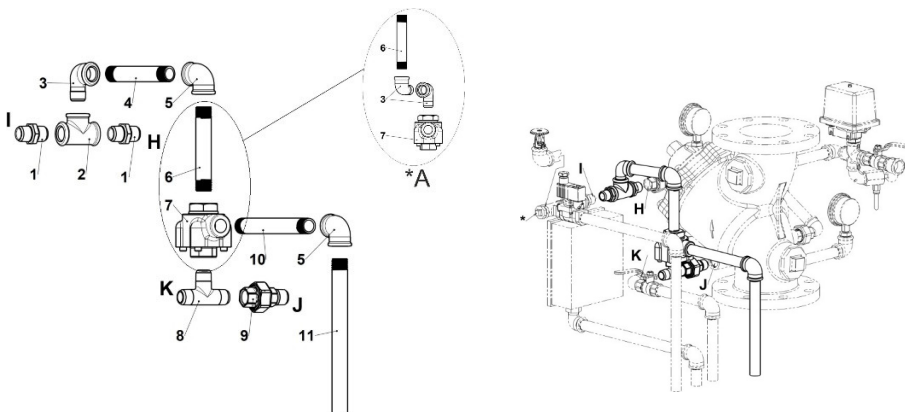

6.7 Fast Drainage

Item	DN50 / 2"	DN80 / 3"	DN100 / 4" DN150 / 6" DN200 / 8"
	Description		
1	Elbow G8-1"- ZN-A	Elbow G8-1/4"- ZN-A	Elbow G8-2"-ZN-A
2	Ball valve 1"	Ball valve 1/4"	Ball valve 2"
3	Elbow A4-1"- Zn- A	Elbow A4-1/4"- Zn-A	Elbow A4-2"- Zn-A

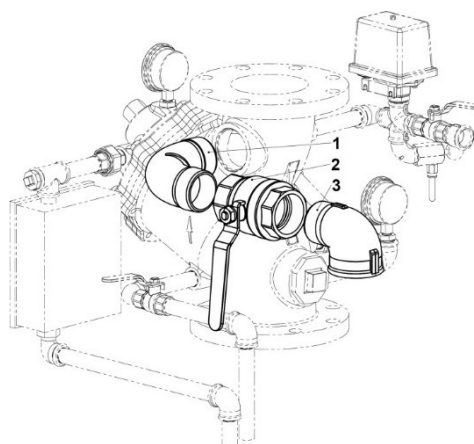

6.8 Inspection and drain connection

Item	DN50 / 2"	DN80 / 3"	DN100 / 4" DN150 / 6" DN200 / 8"
	Description		
1	Elbow G8-1"- ZN-A	Elbow G8-1/4"- ZN-A	Elbow G8-2"-ZN-A
2	Ball valve 1"	Ball valve 1/4"	Ball valve 2"

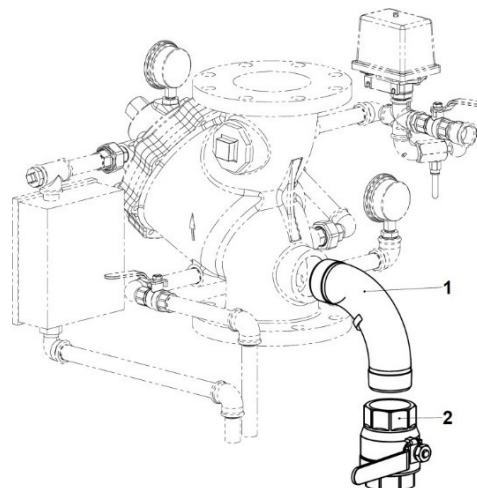



PRODUCT SHEET

FSX-A Deluge Electric, Hydraulic Release



The Viking Corporation (Far East) Pte. Ltd. | 69 Tuas View Square Westlink Techpark, Singapore 637621

ASIA PACIFIC ONLY

7. TECHNICAL DATA – SOLENOID VALVE, MODEL ZB12A (PN 912434)

Maximum Allowable Pressure	20 bar / 290 psi
Opening Time	From ~300ms to ~1500ms
Closing Time	From ~1000ms to ~2000ms
Fluid Temperature	-10°C to +90°C (NBR) 0°C to +130°C (FPM) -10°C to +40°C (EPDM)
Maximum Viscosity	5°E (.37 cStokes or mm ² /s)
Encapsulation Material	PET Fiberglass Reinforced
Insulation Class	F (155°C / 311°F)
Outdoor Protection	IP67 (EN 60529) with plug connector
Ambient Temperature	-10°C to +60°C
Continuous Duty	ED 100%
Electrical Connection	DIN 46340- 3 poles plug connector
Voltage	12-24VDC, 230V/50-60Hz AC
Approvals	UL



Part	Standard Specification
Body	Brass
Sealing	NBR / FPM / EPDM
Internal Component	Brass & Stainless Steel
Seat	Brass
Core Tube	Stainless Steel
Shading Coil	Copper

Note: Solenoid is used only for electric release.

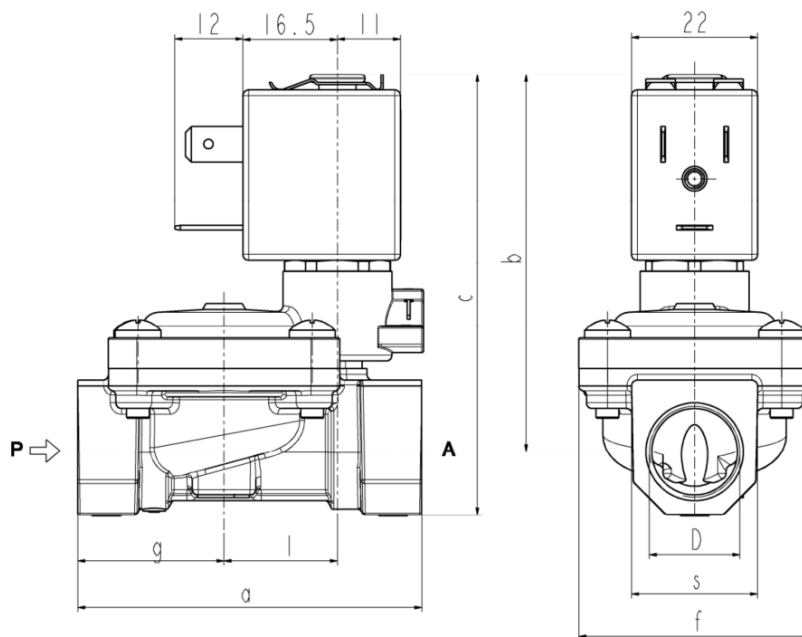

Dimensions (mm)						
a	b	c	f	g	l	s
66	68	82	40	29	20	27

8. SYSTEM OPERATION

In the SET condition

System water supply pressure enters the priming chamber of the deluge valve through the priming line, which includes a normally open priming valve, strainer, restricted orifice and check valve. In the SET condition, water supply pressure is trapped in the priming chamber by check valve, normally closed solenoid valve, and the emergency release. The water supply pressure in the priming chamber holds the Deluge Valve diaphragm closed, keeping the outlet chamber and system piping dry.

In fire conditions

In a fire condition, when the detection system operates, system release control panel energizes solenoid valve to open. Pressure is released from the priming chamber faster than it is supplied through the restricted orifice.

The Deluge Valve diaphragm opens to allow water to flow into the system piping and alarm devices, causing the water motor alarm and water flow alarms connected to the alarm pressure switch (not shown) to activate. Water will flow from any open sprinklers and/or spray nozzles on the system. When the deluge valve operates, water is drained from the PORV inlet. When the differential is overcome, the push rod opens, allowing the prime water to drain.

If a release resets, priming water will continue to escape through the PORV, allowing the deluge valve to continue to operate until the system is reset. The Deluge Valve can only be reset after the system is taken out of service, and the outlet chamber of the deluge valve and associated trim piping are de-pressurised and drained.

In trouble conditions:

If the detection system operates due to mechanical damage or malfunction, the Deluge Valve will open. Water will flow from any open sprinklers and/or spray nozzles on the system. The water motor alarm and alarms connected to alarm pressure switch will activate.

Manual operation

Anytime the emergency release is pulled, pressure is released from the priming chamber and the deluge valve will open. Water will flow into the system piping and alarm devices. Water will flow from any open sprinklers and/or spray nozzles on the system.

9. INSTALLATION

Refer to current Viking Technical Data describing individual components. Also, refer to applicable installation standards, codes, and Authorities Having Jurisdiction.

1. The valve and trim must be installed only in areas where they will not be subjected to freezing temperatures.
2. Alarm pressure switch should activate when pressurized to 4 to 8 PSI (.3 to .6 bar) on pressure rise. Alarm pressure switch should be wired to activate the waterflow alarm.
3. All initiating devices (detectors), indicating appliances, releasing devices, and the system release control panel must be compatible and approved for use with the deluge system that is used. Refer to appropriate Fire Protection Equipment Approval Guides and current Viking Technical Data describing individual components of the Viking Deluge System that is used.

10. PLACING THE SYSTEM IN SERVICE

1. Verify the following:
 - The system main Water Supply Control Valve (not shown) is closed.
 - The system has been properly drained.
 - The emergency release is closed.
2. Close the Drain Valves.

NOTE: For next 2 steps, refer to the 'Installation' section.
3. Opening the priming valve.
4. Establish a normal condition on the release control panel.
5. Slowly and partially open main Water Supply Control Valve (not shown).

NOTE: Opening the main water supply valve too quickly can create excessive pressure causing the valve to trip.
6. Fully open and secure the main Water Supply Control Valve.
7. Verify that all valves are in their normal operating position.
8. Verify that no water is discharging into the drain cup.
9. Check and repair all leaks.
10. On new installations, those systems that have been placed out of service, or where new equipment has been installed, trip test the system to verify that all equipment functions properly. Refer to the section on 'Annual Trip Tests'.
11. After completing a trip test, perform semi-annual maintenance. Refer to the section on 'Maintenance'.

CAUTION

Performing a trip test results in operation of the Deluge Valve. Water will flow into the sprinkler piping. Take necessary precautions to prevent damage.

11. EMERGENCY INSTRUCTIONS

WARNING

Placing a control valve or detection system out of service may eliminate the fire protection capabilities of the system. Prior to proceeding, notify all Authorities Having Jurisdiction (AHJ). Consideration should be given to employment of a fire patrol in the affected areas.

Refer to the appropriate technical data page and NFPA standards for complete care, handling, installation, and maintenance instructions. For additional product and system information, Viking data pages and installation instructions are available on the Viking Web site at www.vikinggroupinc.com.

To take system out of service

After a fire, verify that the fire is OUT and that placing the system out of service has been authorised by the appropriate Authority Having Jurisdiction.

1. Close the Water Supply Control Valve (not shown).

NOTE: Sprinkler systems that have been subjected to a fire must be returned to service as soon as possible. The entire system must be inspected for damage, and repaired or replaced as necessary.

2. Open the system main drain.
3. Close the priming valve
4. Replace any release devices, detectors, sprinklers and/or spray nozzles that have been damaged or have been exposed to fire conditions.
5. Perform all maintenance procedures recommended in Technical Data describing individual components of the system that have operated.
6. Return the system to service as soon as possible. Refer to section on 'Placing the System In Service'.

12. INSPECTIONS, TESTS, AND MAINTENANCE

WARNING

Any system maintenance that involves placing a control valve or detection system out of service may eliminate the fire protection capabilities of that system. Prior to proceeding, notify all Authorities Having Jurisdiction. Consideration should be given to employment of a fire patrol in the affected areas.

NOTICE

The owner is responsible for maintaining the fire protection system and devices in proper operating condition.

The system must be inspected and tested on a regular basis in accordance with NFPA 25. Refer to current Viking Technical Data describing individual components. The frequency of the inspections may vary due to contaminated water supplies, corrosive water supplies, corrosive atmospheres, as well as the condition of the air supply to the system. For minimum maintenance and inspection requirements, refer to NFPA 25. In addition, the Authority Having Jurisdiction may have additional maintenance, testing, and inspection requirements that must be followed.



12. INSPECTIONS, TESTS, AND MAINTENANCE

INSPECTION

Weekly - Viking recommends a weekly visual inspection; check the following items.

- Verify that the main water supply control valve is open and that all other valves are in their normal operating position and appropriately secured.
- Check for signs of mechanical damage, leakage, and/or corrosive activity. If detected, perform maintenance as required. If necessary, replace the device.
- Verify that the valve and trim are adequately heated and protected from freezing and physical damage.

Periodic System Tests

A. Quarterly Water Flow Alarm Test

1. Notify the Authority Having Jurisdiction and those in the area affected by the test.
2. To test the local electric alarm (if provided) and/or mechanical water motor alarm (if provided), OPEN the alarm test valve in the Deluge Valve trim.
 - a. Electric alarm pressure switches (if provided) should activate.
 - b. Electric local alarms should be audible.
 - c. The local water motor gong should be audible.
 - d. If equipped with remote station alarm signaling devices, verify that alarm signals were received.
3. When testing is complete, CLOSE the Alarm Test Valve.
4. Verify the following:
 - a. All local alarms stop sounding and alarm panels (if provided) reset.
 - b. All remote station alarms reset.
 - c. Supply piping to water motor alarm properly drains.
5. Verify that the Alarm Test Valve is CLOSED.
6. Verify that the outlet chamber is free of water. No water should flow from the alarm drain line.
7. Notify the Authority Having Jurisdiction and those in the affected area that testing is complete.

B. Quarterly Main Drain Test

1. Notify the Authority Having Jurisdiction and those in the area affected by the test.
2. Record pressure reading from the Water Supply Pressure Gauge.
3. Verify that the outlet chamber of the Deluge Valve is free of water. No water should flow from the alarm drain line.
4. Fully OPEN the Flow Test Valve.
5. When a full flow is developed from the Flow Test Valve, record the residual pressure from the Water Supply Pressure Gauge.
6. When the test is complete, SLOWLY CLOSE the System Main Water Supply Valve.
7. Compare test results with previous flow information. If deterioration of the water supply is detected, take appropriate steps to restore adequate water supply.
8. Verify:
 - a. Normal water supply pressure has been restored to the inlet chamber, the priming chamber, and the release system. The pressure on the priming chamber water pressure gauge should equal the system water supply pressure.
 - b. All alarm devices and valves are secured in normal operating position.
9. Notify the Authority Having Jurisdiction that the test is complete. Record and/or provide notification of test results as required by the Authority Having Jurisdiction.



12. INSPECTIONS, TESTS, AND MAINTENANCE

C. Annual Trip Test

CAUTION

Performing this test results in operation of the Deluge Valve. Water will flow into the sprinkler piping and from any open sprinklers and/or nozzles. Take necessary precautions to prevent damage.

1. Notify the Authority Having Jurisdiction and those in the area affected by the test.
2. Fully open the Flow Test Valve to flush away any accumulation of foreign material.
3. Close the Flow Test Valve.
4. Trip the system by operating a detector. Allow a full flow to pass through the Deluge Valve. Water flow alarms should operate.
5. When test is complete:
 - a. Close the Main Water Supply Control Valve.
 - b. Close the Priming Valve.
 - c. Open all system main drains. Allow the system to drain completely.
6. Perform semi-annual maintenance. Refer to section 'Semi-Annual Maintenance'.
7. Place the system in service. Refer to section: 'Placing the System in Service'.
8. Notify the Authority Having Jurisdiction that the test is complete. Record and/or provide notification of test results as required by the Authority Having Jurisdiction.

MAINTENANCE

After Each Operation

1. Sprinkler systems that have been subjected to a fire must be returned to service as soon as possible. The entire system must be inspected for damage, and repaired or replaced as necessary.
2. Deluge Valves and trim that have been subjected to brackish water, salt water, foam/water solution, or any other corrosive water supply, should be flushed with good quality fresh water before being returned to service.
3. Perform semi-annual maintenance after every operation.

Semi-Annually

1. Remove the system from service.
2. Close the Main Water Supply Control Valve.
3. Relieve pressure in the priming chamber by opening the Emergency Release.
4. Inspect all trim for signs of corrosion and/or blockage. Clean and/or replace as required.
5. Clean and/or replace all strainer screens.
6. Refer to section Placing the System in Service.

Every Fifth Year

1. Internal inspection of Deluge Valves is recommended every five years unless inspections and tests indicate more frequent internal inspections are required. Refer to the Model FSX-A Valve Technical Data Page.
2. Internal inspection of strainers, and restricted orifices is recommended every five years unless inspections and tests indicate more frequent internal inspections are required.
3. Record and provide notification of inspection results as required by the Authority Having Jurisdiction.