

1. DESCRIPTION

Viking FSX-A Double Interlocked Preaction Systems with Electric/Pneu-Lectric release utilize a Viking deluge valve, pneumatic supervision of the automatic sprinkler system via pressurized air/nitrogen, and an electric detection system. The deluge valve release trim utilizes a normally closed electric solenoid valve controlled by an approved release control panel with two initiating circuits configured for "cross-zoned" operation. One initiating circuit is connected to the electric detection system; the other to a "low-air" supervisory switch.

BOTH the electric detection system and air/nitrogen pressure must be relieved from the sprinkler system before the deluge valve will open to fill the sprinkler system with water. If the electric detection system (alone) operates, an alarm will activate but the deluge valve will NOT open. If the sprinkler piping is damaged or a sprinkler is broken or fused, but the detection system has not activated, an alarm will activate, but the deluge valve will NOT open.

In fire conditions, after both the detection system and a sprinkler operate, the deluge valve opens, allowing water to enter the system.

Electric/pneu-lectric double interlocked preaction systems are commonly used as refrigerated area systems. They are also commonly used where flooding of the sprinkler system piping can have serious consequences and where it is important to control accidental water discharge due to damaged sprinkler piping.

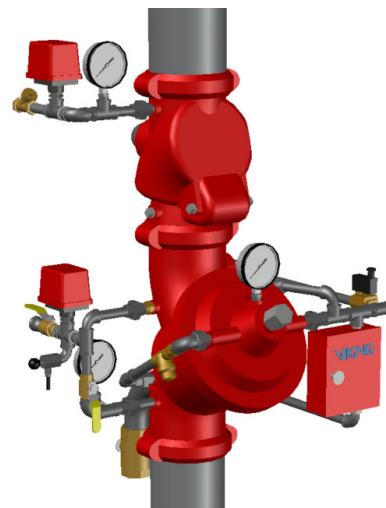

2. DIMENSIONS

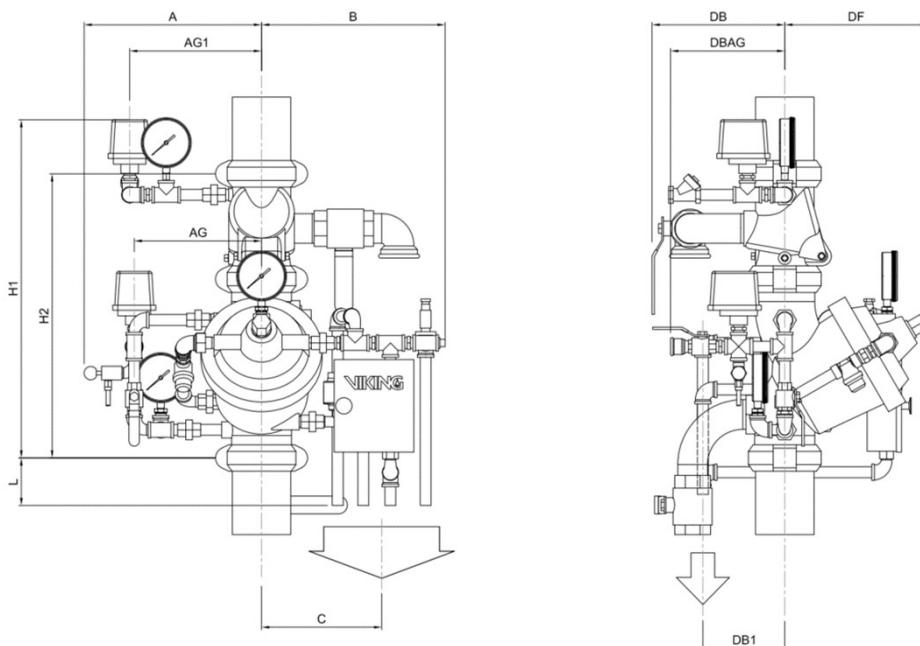

	DN50 / 2"	DN80 / 3"	DN100 / 4"	DN150 / 6"	DN200 / 8"
A	360	370	340	370	405
AG	270	270	255	270	300
AG1	225	240	260	290	320
B	340	350	350	390	490
C	340	290	290	330	380
L	150	120	90	15	10
H1	565	615	662	905	1060
H2	452	507	556	805	972
DF	210	250	280	335	450
DB	155	200	260	310	330
DBAG	190	190	190	190	190
DB1	140	150	160	170	180



ASIA PACIFIC ONLY

3. SYSTEM COMPONENTS

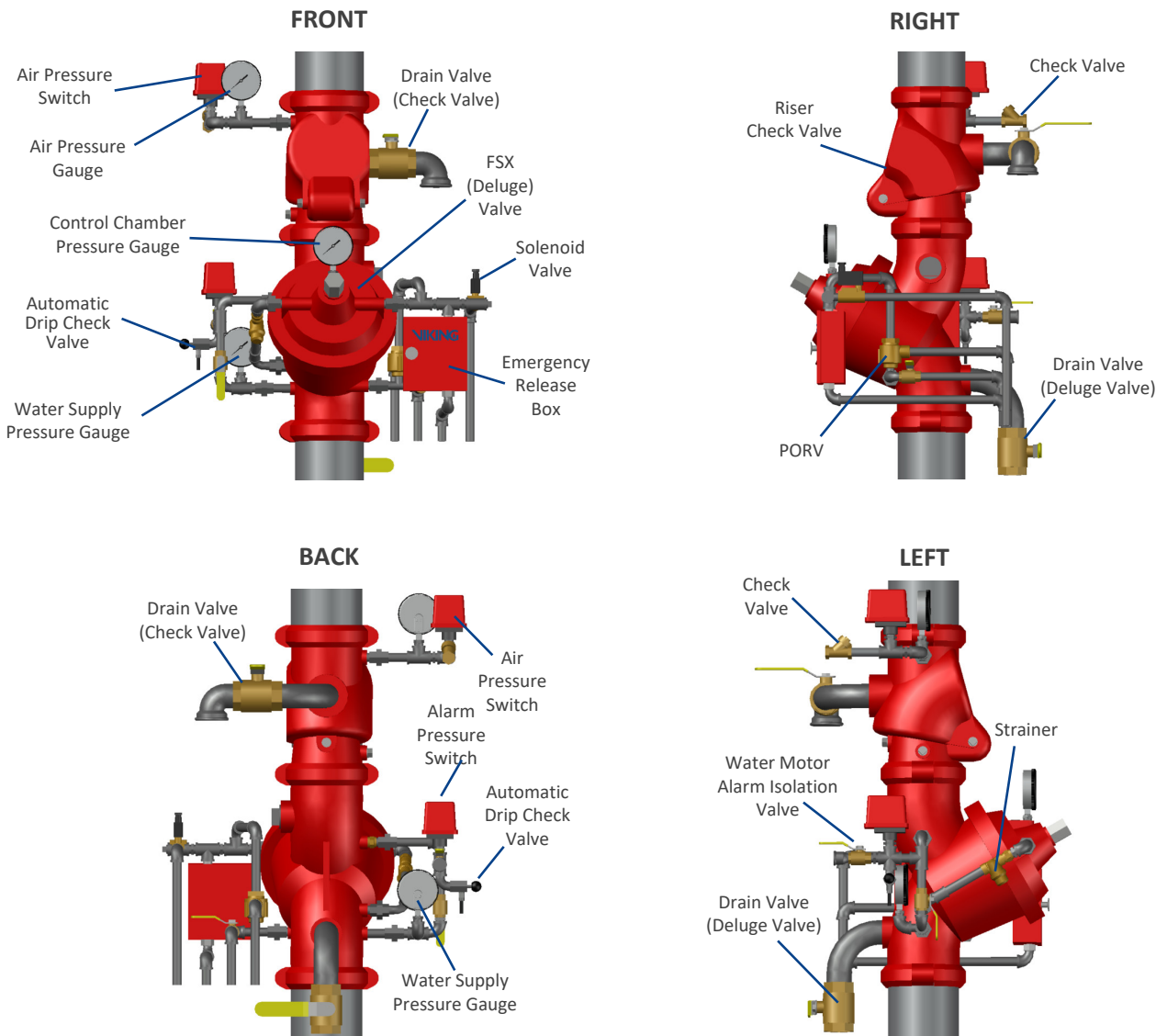

Item	Function
Alarm Pressure Switch	Enables monitoring through the fire detection control panel if the deluge valve has triggered.
Automatic Drip Check Valve	Automatic draining of the alarm line.
Check Valve	Prevents water flow through the air pressure monitoring line when the deluge valve is activated.
Control Chamber Pressure Gauge	Displays control chamber water pressure. Pressure should be greater or equal to water supply pressure.
Drain Valve (Check Valve)	Valve to drain water from the system and check valve.
Drain Valve (Deluge Valve)	Used to test water supply upstream of the deluge valve according to NFPA regulations. Used to drain water from deluge valve.
Emergency Release Box	To enable the system to be triggered manually.
PORV (Pressure Operated Relief Valve)	Prevents accidental closing of the deluge valve in event of a fire and in case of an accidental interruption of power supply to the solenoid valve.
System Air Pressure Gauge	Displays the air pressure in the system.
Solenoid Valve	Is activated by the fire detection control panel and activates the system.
Strainer	Filters the water supplied to the release devices.
Water Motor Alarm Test Valve	Used to test the water motor alarm and alarm pressure switch without flooding the system.
Water Motor Isolation Valve	Used to shut off the water motor alarm.
Water Supply Pressure Gauge	Displays the pressure of the water supply
Water Motor Alarm Test Valve	Used to test the water motor alarm and alarm pressure switch without flooding the system.
Water Motor Isolation Valve	Used to shut off the water motor alarm.

5. ORDERING INFORMATION

Part Number	Description	2" DN50	3" DN80	4" DN100	6" DN150	8" DN200
PREACTION VALVE						
VKD050GG060MM	2" Deluge Valve Model FSX-A Grooved 60mm UL/FM	X				
VKD080GG089MM	3" Deluge Valve Model FSX-A Grooved 89mm UL/FM		X			
VKD100GG114MM	4" Deluge Valve Model FSX-A Grooved 114mm UL/FM			X		
VKD150GG165MM OR	6" Deluge Valve Model FSX-A Grooved 165mm UL/FM OR				X	
VKD150GG168MM	6" Deluge Valve Model FSX-A Grooved 168mm UL/FM					
VKD200GG219MM	8" Deluge Valve Model FSX-A Grooved 219mm UL/FM					X
HYDRAULIC TRIM ASSEMBLY (includes PORV, fast drainage set, alarm test set, emergency manual release, pressure gauges)						
VKT050UL	2" Hydraulic Actuation Trim Set	X				
VKT080UL	3" Hydraulic Actuation Trim Set		X			
VKT100UL	4" Hydraulic Actuation Trim Set			X		
VKT150UL	6" Hydraulic Actuation Trim Set				X	
VKT200UL	8" Hydraulic Actuation Trim Set					X
ELECTRICAL TRIM ASSEMBLY (excludes solenoid valve)						
VKSV050TA	2" Electrical Actuation Trim Set	X				
VKSV080TA	3" Electrical Actuation Trim Set		X			
VKSV100TA	4" Electrical Actuation Trim Set			X		
VKSV150TA	6" Electrical Actuation Trim Set				X	
VKSV200TA	8" Electrical Actuation Trim Set					X
TEST CONNECTION						
VKTCS050	1" Test Connection Set (for 2" Valve)	X				
VKTCS080	1½" Test Connection Set (for 3" Valve)		X			
VKTCS100-200	2" Test Connection Set (for 4", 6" 8" Valve)			X	X	X
CHECK VALVE, Model SCG						
RH84XF4D60	Model SCG, 2" 60mm Grooved Check Valve with 1" Drain Hole	X				
RH84XF4D89	Model SCG, 3" 89mm Grooved Check Valve with 1½" Drain Hole		X			
RH84XF4D114	Model SCG, 4" 114mm Grooved Check Valve with 2" Drain Hole			X		
RH84XF4D165 OR	Model SCG, 6" 165mm Grooved Check Valve with 2" Drain Hole OR				X	
RH84XF4D168	Model SCG, 6" 168mm Grooved Check Valve with 2" Drain Hole					
RH84XF4D219	Model SCG, 8" 219mm Grooved Check Valve with 2" Drain Hole					X
PREACTION TRIM ASSEMBLY (complete with Pressure Gauge)						
VKPAEPL050	2" Pre-action Trim SI Electric & DI Electric/Pneu-Lectric Release	X				
VKPAEPL080	3" Pre-action Trim SI Electric & DI Electric/Pneu-Lectric Release		X			
VKPAEPL100	4" Pre-action Trim SI Electric & DI Electric/Pneu-Lectric Release			X		
VKPAEPL150	6" Pre-action Trim SI Electric & DI Electric/Pneu-Lectric Release				X	
VKPAEPL200	8" Pre-action Trim SI Electric & DI Electric/Pneu-Lectric Release					X
ALARM PRESSURE						
1340101 / 1340103 OR	PS101A / PS10-1 Pressure Switch (Single Contact), UL/FM OR	X	X	X	X	X
1340401 / 1340403	PS401A / PS10-2 Pressure Switch (single contact), UL/FM					
LOW AIR PRESSURE						
1340401 / 1340403 OR	PS401A / PS40-1 Pressure Switch (single contact), UL/FM ¹ OR	X	X	X	X	X
1340402 / 1340404	PS402A / PS40-2 Pressure Switch (dual contact), UL/FM					
OTHERS						
912434	Model ZB12A, Solenoid Valve NC 24V including Plug	X	X	X	X	X
07862	Water Motor Alarm Gong	X	X	X	X	X
AIR MAINTENANCE DEVICE (CHOOSE 1 ONLY)						
07459	VIKING Model D-2 Air Maintenance Device					
AMD-1	GENERAL AIR Model AMD-1 Air Maintenance Device					
AMD-2	GENERAL AIR Model AMD-2 Air Maintenance Device ²					
AIR COMPRESSOR						
Refer to the air compressor datasheets						
SPARE PARTS						
VKATS050-200	2", 3", 4", 6", 8" Alarm Test Set					
16970	Pressure Operated Relief Valve (PORV) D3					
01553C	Emergency Manual Release Box Model C1					
911692	Pressure Gauge 300PSI-1 / 4BSP- Type 711					

Note: Programming of the Fire Extinguishing Panel is required. Flange Adapters are available as option.

¹ For dual contact requirements, please use PS 40-2 or PS402A

² For compressor or tank without an integrated pressure switch

6. DELUGE VALVE ASSEMBLY

6.1 Control chamber pressure gauge

DN50 / 2" to DN200 / 8"	
Item	Description
1	Pressure gauge
2	Red. -nipple N4- 1/2"x1/4-Zn-A

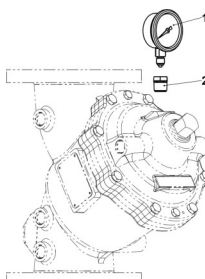

6.2 Bypass Connection

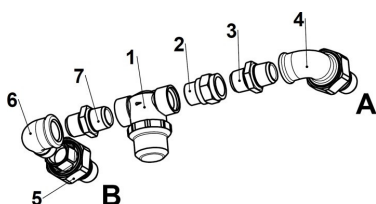

DN50 / 2"	
Item	Description
1	Strainer 1/2"
2	Check valve G1/2"-I/A
3*	Orifice 1/2" 3.5mm
4	Union UA12-1/2"-Zn-A
5	Union U12-1/2"-Zn-A
6	Elbow A4-1/2"-Zn-A
7*	Hex. nipple N8-1/2"-Zn-A

* Do NOT mix up Pos. 3 with Pos. 7

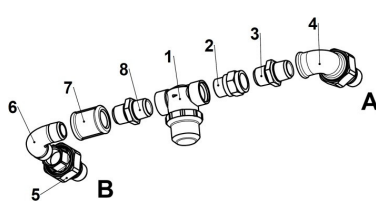

DN80 / 3"	
Item	Description
1	Strainer 1/2"
2	Check valve G1/2"-I/A
3*	Orifice 1/2" 3.5mm
4	Union UA12-1/2"-Zn-A
5	Union U12-1/2"-Zn-A
6	Elbow G8-1/2"-Zn-A
7	Socket M2-1/2"-Zn-A
8*	Hex. nipple N8-1/2"-Zn-A

* Do NOT mix up Pos. 3 with Pos. 8

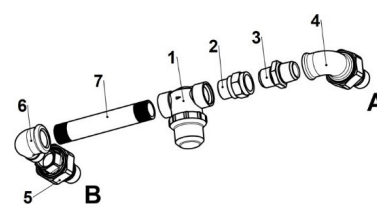

DN100 / 4"	
Item	Description
1	Strainer 1/2"
2	Check valve G1/2"-I/A
3	Orifice 1/2" 3.5mm
4	Union UA12-1/2"-Zn-A
5	Union U12-1/2"-Zn-A
6	Elbow A4-1/2"-Zn-A
7	Pipe nipple 1/2"-Zn

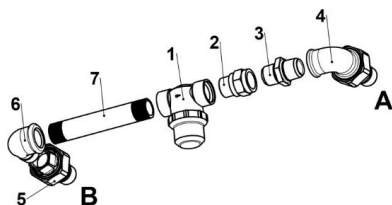

DN100 / 4"	
Item	Description
1	Strainer 1/2"
2	Check valve G1/2"-I/A
3	Orifice 1/2" 3.5mm
4	Union UA12-1/2"-Zn-A
5	Union U12-1/2"-Zn-A
6	Elbow A4-1/2"-Zn-A
7	Pipe nipple 1/2"-Zn

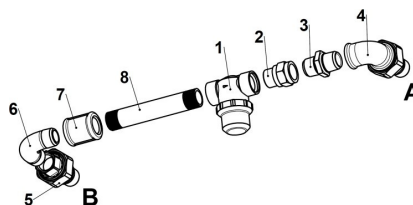

DN150 / 6"	
Item	Description
1	Strainer 1/2"
2	Check valve G1/2"-I/A
3	Orifice 1/2" 3.5mm
4	Union UA12-1/2"-Zn-A
5	Union U12-1/2"-Zn-A
6	Elbow A4-1/2"-Zn-A
7	Socket 1/2"-Zn-A
8	Pipe nipple 1/2"-Zn

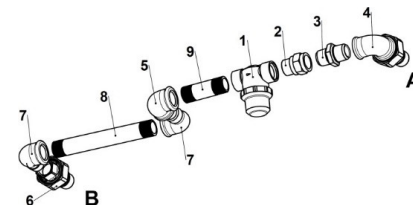

DN200 / 8"	
Item	Description
1	Strainer 1/2"
2	Check valve G1/2"-I/A
3	Orifice 1/2" 3.5mm
4	Union UA12-1/2"-Zn-A
5	Union U12-1/2"-Zn-A
6	Elbow A4-1/2"-Zn-A
7	Socket 1/2"-Zn-A
8	Pipe nipple 1/2"-Zn
9	Pipe nipple 1/2"-Zn

6. DELUGE VALVE ASSEMBLY

6.3 Water Supply pressure gauge

DN50 / 2" to DN200 / 8"	
Item	Description
1*	Pipe nipple 1/2"-Zn
2	Elbow A1-1/2"-Zn-A
3	Red.- nipple N4-1/2"x1/4"-ZN-A
4	Pressure gauge

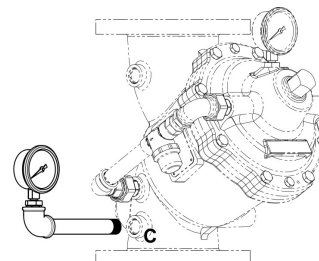
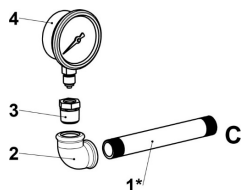

*The pipe nipple is not required if the alarm test equipment is installed.

6.4 Alarm Line

DN50 / 2" to DN200 / 8"	
Item	Description
1	Pipe nipple 1/2"-Zn
2	Elbow A4-1/2"-Zn-A
3	Cross union A1-1/2"-Zn-A
4*	Hex. nipple N8-1/2"-Zn-A
5	Ball valve 1/2"
6	Socket N4- 3/4"x1/2"-Zn-A
7*	Alarm pressure switch
8	Elbow 94-1/2"-Zn
9	Drain valve

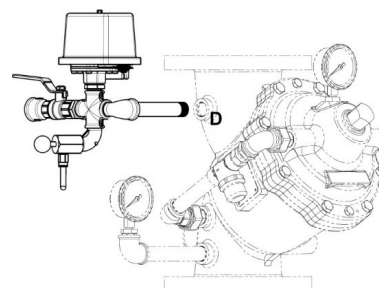
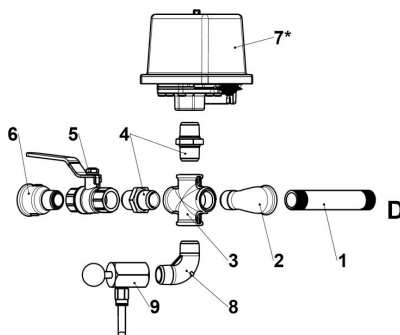

*If a pressure switch (Pos. 7) with an outer thread is used, the Hex. nipple located underneath (Pos. 4) is not required.

6.5 Manual Release

DN50 / 2" to DN200 / 8"	
Item	Description
1	Union U12-1/2"-Zn-A
2	Pipe nipple 1/2"-Zn
3	Tee A1-1/2"-Zn-A
4*	Plug T9-1/2"-Zn-A
5	Emergency release box
6	Elbow A4-1/2"-Zn-A
7*	Pipe nipple 1/2"
8	Elbow A1-1/2"-Zn-A
9	Pipe nipple 1/2"

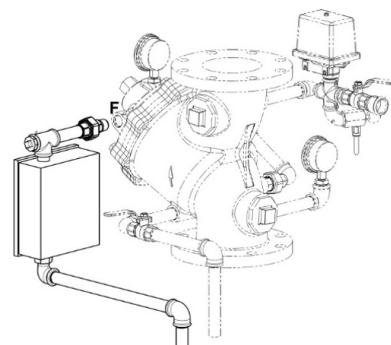
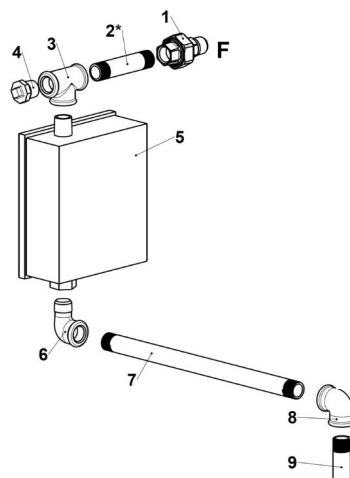

6. DELUGE VALVE ASSEMBLY

6.6 Pressure operated relief valves (PORV)

DN50 / 2" to DN200 / 8"	
Item	Description
1	Hex. nipple N8-1/2"-Zn-A
2	Tee 133-1/2"-Zn
3	Elbow A4-1/2"-Zn-A
4	Pipe nipple 1/2"
5	Elbow A1-1/2"-Zn-A
6	Pipe nipple 1/2"
7	Diaphragm valve PORV D3
8	Tee 135-1/2"-Zn
9	Union U12-1/2"-Zn-A
10	Pipe nipple 1/2"
11	Pipe nipple 1/2"

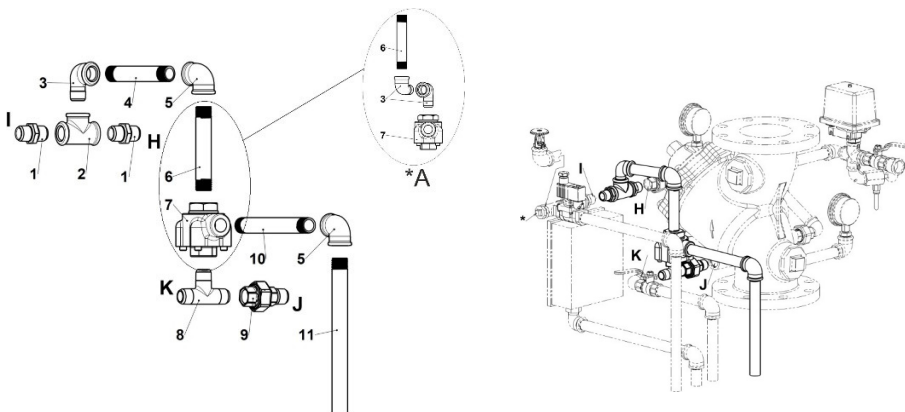

6.7 Fast Drainage

	DN50 / 2"	DN80 / 3"	DN100 / 4" DN150 / 6" DN200 / 8"
Item	Description		
1	Elbow G8-1"-ZN-A	Elbow G8-1/4"-ZN-A	Elbow G8-2"-ZN-A
2	Ball valve 1"	Ball valve 1/4"	Ball valve 2"
3	Elbow A4-1"-Zn-A	Elbow A4-1/4"-Zn-A	Elbow A4-2"-Zn-A

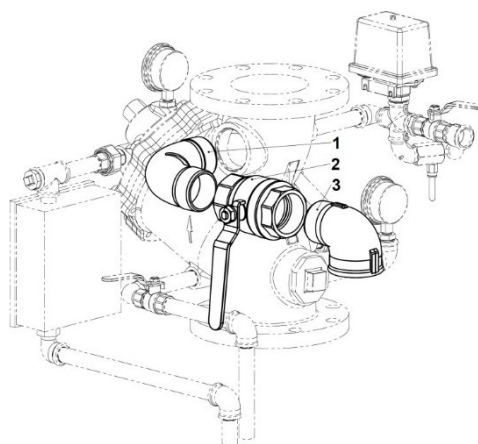

6.8 Inspection and drain connection

	DN50 / 2"	DN80 / 3"	DN100 / 4" DN150 / 6" DN200 / 8"
Item	Description		
1	Elbow G8-1"-ZN-A	Elbow G8-1/4"-ZN-A	Elbow G8-2"-ZN-A
2	Ball valve 1"	Ball valve 1/4"	Ball valve 2"

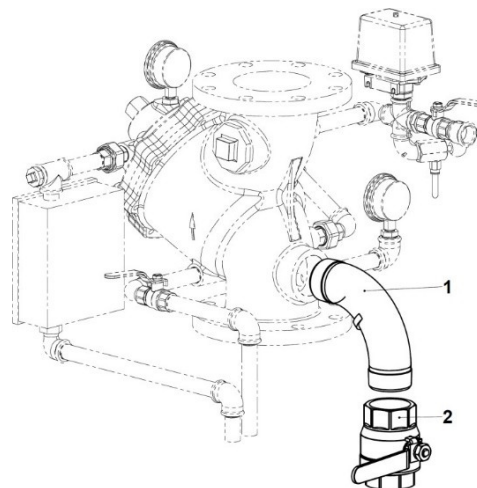

7. CHECK VALVE ASSEMBLY DIAGRAM

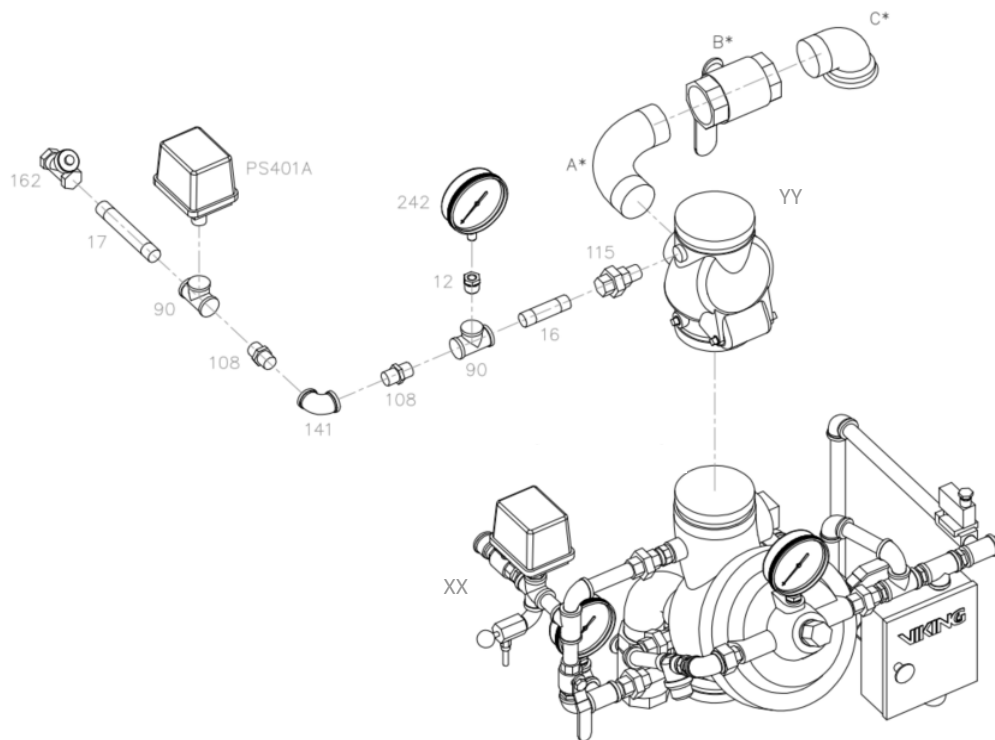

ITEM NUMBER	DESCRIPTION	ITEM NUMBER	DESCRIPTION
12	Reducer Galvanised ½" x ¼" MF	162	Check Valve ½"
16	Pipe ½" x 60mm	242	Water Gauge 0-300 psi 0-20 Bar ¼" NPT
17	Pipe ½" x 80mm	YY	Riser Check Valve
90	Tee ½"	XX	FSX-A Deluge Valve – Electric Release Assembly ¹
108	Nip Hex Galvanised ½"	*A	Elbow G8-2"-ZN-A
115	Union ½" M-F	*B	Ball Valve 2"
141	Elbow ½" M-F	*C	Elbow A4-2"-ZN-A

¹ Refer to Section6 for FSX-A Deluge Valve Data Sheet for assembly drawing.

* Components to be removed from FSX-A Deluge Valve – Electric Release Assembly and assembled as shown in drawings.

7. TECHNICAL DATA – DELUGE VALVE, MODEL FSX-A

7.1 Technical Data

Valve Type	Hydraulically operated quick opening differential type
Nominal Diameter	2" / DN50 , 3" / DN80 , 4" / DN100 , 6" / DN150 , 8" / DN200
Working Pressure	250psi / 17.2 bar (UL) 232 psi / 16.0 bar (FM)
Flange Connection	ANSI B16.5 Class 150 / DIN ISO in accordance with DIN EN 1092
Grooved Connection	Metric, AWWA C606 Standard
Installation Position	Vertical
Medium	Fresh Water / Foam Water Mixture
Valve Approvals	cULus, FM
Operating Temperature	4°C / 39°F - 60°C / 140°F



7.2 Parts

- | | |
|---------------------|-------------------------|
| 1. Housing | 14. Pressure spring |
| 2. Valve seat | 15. Guide plug |
| 3. Guide bearing | 16. O-ring |
| 4. Cover | 17. O-ring |
| 5. Guide bush | 18. O-ring |
| 6. Valve rod | 19. Hexagon bolt |
| 7. Valve disc | 20. Hexagon bolt |
| 8. Gasket | 21. Nameplate* |
| 9. Holding disc | 22. Grooved drive stud* |
| 10. O-ring | 23. Threaded plug |
| 11. Hexagon Nut | |
| 12. Supporting Disc | |
| 13. Diaphragm | |

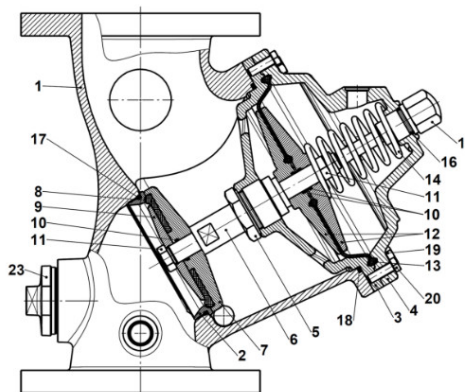

* Not visible on illustration

7.3 Friction Loss

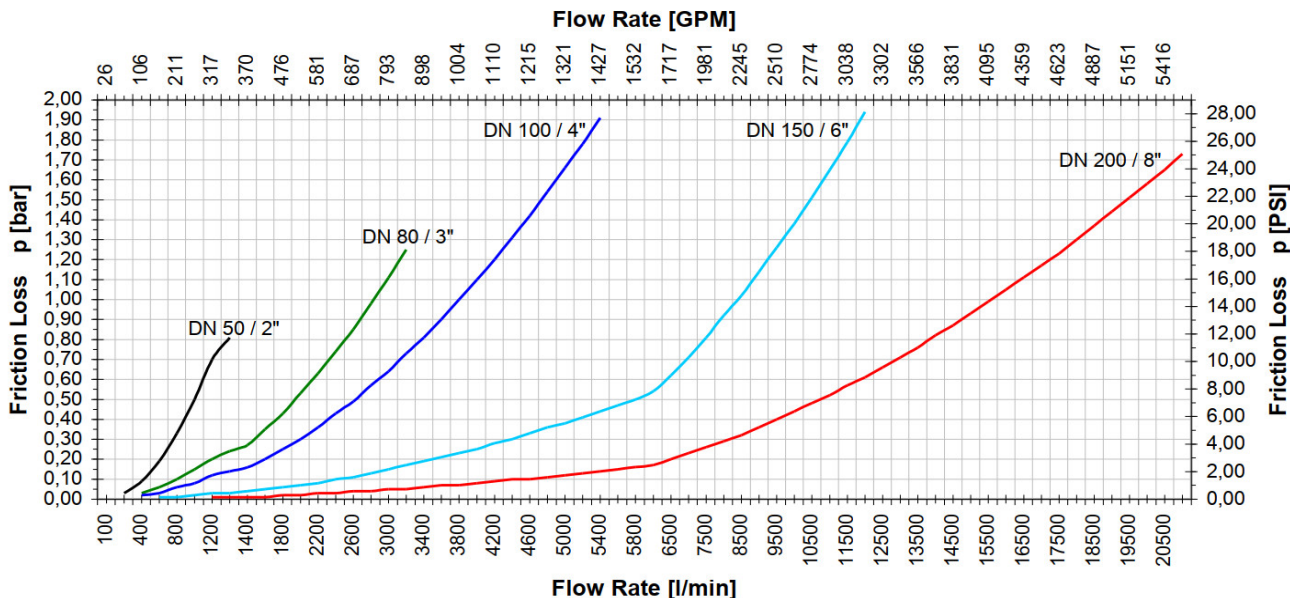

7. TECHNICAL DATA – DELUGE VALVE, MODEL FSX-A
7.4 Materials

Valve Body	Ductile Iron
Valve Seat	Brass
Piston Rod	Stainless Steel
Valve Disc	Brass
Diaphragm	NBR fire reinforced
Gaskets NBR	4°C / 39°F - 60°C / 140°F
Finish	RAL 300 Primer & Clear Coat

7.5 Pressures & Flowrates

Pressure		Flow Velocity	
Bar	PSI	m/sec	ft/sec
2.0	29.0	5	16.4
2.5	36.0	7	23.0
3.0	43.5	8	26.2
3.8	55.0	10	32.8

7.5 Flowrate & Velocity

Valve Size		DIN EN 10220	V		Q	
Inch	DN	mm	m/s	ft/s	ltr/min	gpm
2	50	60.3 x 2.6	10	32.8	1,340	354
3	80	88.9 x 2.9	10	32.8	3,195	844
4	100	114.3 x 3.2	10	32.8	5,427	1,434
6	150	168.3 x 4.0	10	32.80	12,050	3,184
8	200	219.1 x 4.5	10	32.8	20,742	5,480

Valve Size		Schedule 40	V		Q	
Inch	DN	mm	m/s	ft/s	ltr/min	gpm
2	50	60.3 x 3.91	10	32.8	1,240	328
3	80	88.9 x 5.49	10	32.8	2,802	740
4	100	114.3 x 6.02	10	32.8	4,869	1,286
6	150	168.3 x 7.11	10	32.80	11,128	2,940
8	200	219.1 x 8.18	10	32.8	19,340	5,110

7.6 Pipe Equivalent Length

Valve Size		DIN EN 10220	Equivalent Length		Δp		Q	
Inch	DN	mm	m	ft	bar	psi	ltr/min	gpm
2	50	60.3 x 2.6	4.65	15.26	0.18	2.63	594	157
3	80	88.9 x 2.9	10.63	34.87	0.24	3.54	1,310	346
4	100	114.3 x 3.2	21.96	72.05	0.38	5.44	2,256	596
6	150	168.3 x 4.0	34.96	114.70	0.40	5.85	5,114	1,351
8	200	219.1 x 4.5	41.38	135.76	0.35	4.99	8,854	2,339

Valve Size		Schedule 40	Equivalent Length		Δp		Q	
Inch	DN	mm	m	ft	bar	psi	ltr/min	gpm
2	50	60.3 x 3.91	3.67	12.04	0.18	2.63	594	157
3	80	88.9 x 5.49	7.77	25.49	0.24	3.54	1,310	346
4	100	114.3 x 6.02	16.91	55.48	0.38	5.44	2,256	596
6	150	168.3 x 7.11	28.83	94.59	0.40	5.85	5,114	1,351
8	200	219.1 x 8.18	34.78	114.11	0.35	4.99	8,854	2,339



8. TECHNICAL DATA – SWING CHECK VALVE, MODEL SCG

8.1 Technical Data

Sizes (PN)	2"/DN50 (RH84XFD60), 3"/DN80 (RH84XFD89), 4"/DN100 (RH84XFD114), 6"/DN150 (RH84XFD165/168), 8"/DN200 (RH84XFD219)
Working Pressure	300 psi / 21bar (UL & FM)
Working Temperature	0°C to 80°C (32°C to 176°C)
Finish	Fusion bonded epoxy coated, internal and external
Material (body)	Ductile iron
Connections	Grooved, AWWA C606, ISO 6182
Approvals	cULus



8.2 Materials

Item	Part	Standard Specification	Option
1	Valve body	ASTM A536,65-45-12	
2	Hinge pin	AISI420	
3	Spring	AISI304	AISI 316
4	Eye Bolt	Stainless Steel	
5	Disc	DN50-100: AIS304 DN150-200: ASTM A 536, 65-45-12	
6	Disc Sealing Ring	EPDM	NBR
7	Seat Ring	ASTM B62 C83600 (Pressed Fit)	AISI304, AISI316 Pressed Fit or Threaded
8	Plug	Malleable Iron Galvanized	Bronze ASTM B584
9	Plug	Malleable Iron Galvanized	Bronze ASTM B584
10	Plug	Malleable Iron Galvanized	Bronze ASTM B584
11	Plug	Malleable Iron Galvanized	Bronze ASTM B584
12	Bolt	AISA304	AISI316
13	Washer	AISA304	AISI316
14	Nut	AISA304	AISI316

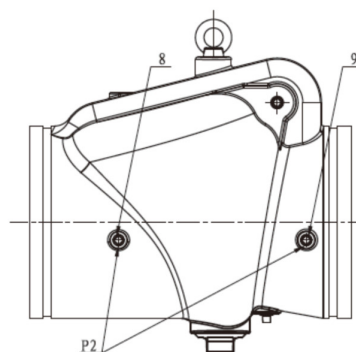
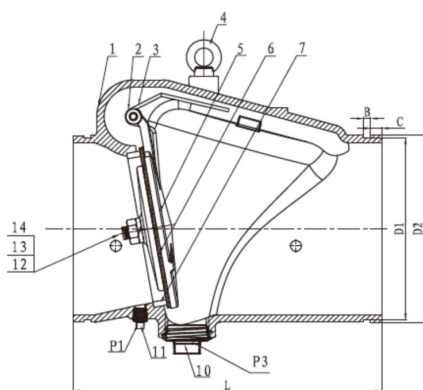

Size	Dimensions (mm)							
	L	D1	D2	B	C	P1	P2	P3
2"/DN50	171	57.5	60.3	7.93	15.88	1/2-14NPT	3/8-18NPT	1/2-14NPT
3"/DN80	197	84.94	88.9	7.93	15.88	1/2-14NPT	3/8-18NPT	1/2-14NPT
4"/DN100	210	110.08	114.3	9.53	15.88	1/2-14NPT	2-11.5NPT	1/2-14NPT
6"/DN150	324	163.96	168.3	9.53	15.88	1/2-14NPT	2-11.5NPT	1/2-14NPT
8"/DN200	371	214.4	219.1	11.13	19.05	1/2-14NPT	2-11.5NPT	1/2-14NPT

9. TECHNICAL DATA – SOLENOID VALVE, MODEL ZB12A (PN 912434)
9.1 Technical Data

Maximum Allowable Pressure	20 bar / 290 psi
Opening Time	From ~300ms to ~1500ms
Closing Time	From ~1000ms to ~2000ms
Fluid Temperature	-10°C to +90°C (NBR) 0°C to +130°C (FPM) -10°C to +40°C (EPDM)
Maximum Viscosity	5°E (.37 cStokes or mm ² /s)
Encapsulation Material	PET Fiberglass Reinforced
Insulation Class	F (155°C / 311°F)
Outdoor Protection	IP67 (EN 60529) with plug connector
Ambient Temperature	-10°C to +60°C
Continuous Duty	ED 100%
Electrical Connection	DIN 46340- 3 poles plug connector
Voltage	12-24VDC, 230V/50-60Hz AC
Approvals	UL

9.2 Materials

Part	Standard Specification
Body	Brass
Sealing	NBR / FPM / EPDM
Internal Component	Brass & Stainless Steel
Seat	Brass
Core Tube	Stainless Steel
Shading Coil	Copper

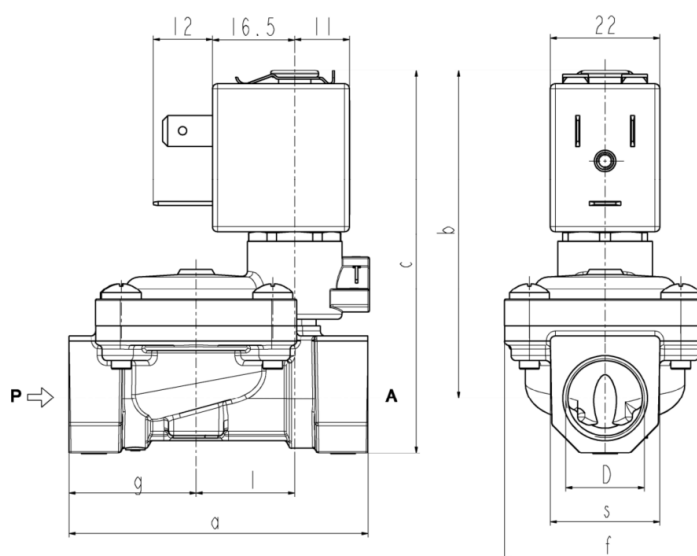

Dimensions (mm)						
a	b	c	f	g	l	s
66	68	82	40	29	20	27

10. SYSTEM OPERATION

In the SET condition

System water supply pressure enters the priming chamber of the deluge valve through the priming line, which includes a normally open priming valve, strainer, restricted orifice and check valve. In the SET condition, water supply pressure is trapped in the priming chamber by check valve, normally closed solenoid valve, and the emergency release. The water supply pressure in the priming chamber holds the Deluge Valve diaphragm closed, keeping the outlet chamber and system piping dry.

In fire conditions

In a fire condition, when the detection system operates, system release control panel energizes solenoid valve open. Alarms activate, but the deluge valve will NOT open until a sprinkler opens relieving air/nitrogen pressure from the sprinkler system. When a sprinkler opens, supervisory pressure in the sprinkler piping is reduced causing the pneumatic actuator to open. After BOTH the electric detection system activates AND air/nitrogen in the sprinkler system has been lost, pressure is released from the priming chamber faster than it is supplied through restricted orifice. The deluge valve diaphragm opens to allow water to flow into the system piping and alarm devices, causing water motor alarm and water flow alarms connected to alarm pressure switch to activate.

When the deluge valve operates, water is drained from the PORV inlet. When the pressure differential is overcome, the push rod opens, allowing the prime water to drain. If a release resets, priming water will continue to escape through the PORV, allowing the deluge valve to continue to operate until the system is reset. The Deluge Valve can only be reset after the system is taken out of service, and the outlet chamber of the deluge valve and associated trim piping are depressurized and drained.

In trouble conditions:

If a sprinkler opens prior to operation of the detection system, or any time supervisory pressure in the sprinkler piping is lost, the air supervisory switch will signal a low air pressure condition, but the deluge valve will NOT open. If the electric detection system operates due to mechanical damage or malfunction, the deluge valve will NOT open.

Manual operation

Anytime the emergency release is pulled, pressure is released from the priming chamber and the deluge valve will open. Water will flow into the system piping and alarm devices. Water will flow from any open sprinklers and/or spray nozzles on the system.

11. INSTALLATION

Refer to current Viking Technical Data describing individual components. Also, refer to applicable installation standards, codes, and Authorities Having Jurisdiction.

Important Settings

NOTE: Installation Standards may allow air/nitrogen pressures lower than those recommended below. When using air/nitrogen pressures lower than the recommended setting noted below, verify that the air regulation equipment and air supervisory switches used are compatible with the air/nitrogen pressure setting used.

Device	System Water Pressure
	Up to 175 psi / 12 bar
	Set to Maintain:
Air Compressor On/Off Switch	ON: 30 psi / 2 bar OFF: 40 psi / 2.8 bar
Air Maintenance Device (release system)	30 psi / 2 bar
Air Pressure Supervisory Switch (release system)	25 psi / 1.7 bar
Alarm pressure switch	4 – 8 psi / 0.3 – 0.6 bar

Air Supply Design

The air supply compressor should be sized to establish total required air pressure in 30 minutes. The air supply must be regulated, restricted, and maintained automatically. The air maintenance device is used to regulate and restrict the flow of supervisory air into the sprinkler system piping.

The air supply must be regulated to maintain the pressure desired in the release system. Pressure settings other than those recommended above may affect operation of the system. The air supply must be restricted to ensure that the automatic air supply cannot replace air as fast as it escapes when a releasing device operates.

It is recommended practice to provide an inspectors test connection on the pneumatic release system. The inspectors test connection should be equipped with a ball valve (normally locked closed) capable of being opened to simulate the opening of a releasing device. Locate the connection and valve at the highest, most demanding location of the release system. Test connections provided on pneumatic release systems should terminate in an orifice equal to the smallest orifice of the releasing devices provided. The inspectors test connection may be used to verify that the automatic air supply cannot replace air as fast as it escapes when a releasing device operates. Refer to section on 'Inspection, Tests, and Maintenance'.

Speed of Operation:

An optional accelerator may be installed to allow the system to fill with water faster. An accelerator may be necessary to meet water delivery time requirements.



12. PLACING THE SYSTEM IN SERVICE

1. Verify the following:
 - The system main Water Supply Control Valve (not shown) is closed.
 - The system has been properly drained.
 - The emergency release is closed.
2. Close the Drain Valves.

NOTE: For next 2 steps, refer to the 'Installation' section.
3. Restore supervisory pressure to the sprinkler piping. Verify that the ½" valve in the air maintenance device by-pass trim is closed and that both the ¼" valves are open.
4. Establish a normal condition on the release control panel.
5. Slowly and partially open main Water Supply Control Valve (not shown).

NOTE: Opening the main water supply valve too quickly can create excessive pressure causing the valve to trip.
6. Fully open and secure the main Water Supply Control Valve.
7. Verify that all valves are in their normal operating position.
8. Verify that no water is discharging into the drain cup.
9. Check and repair all leaks.
10. On new installations, those systems that have been placed out of service, or where new equipment has been installed, trip test the system to verify that all equipment functions properly. Refer to the section on 'Annual Trip Tests'.
11. After completing a trip test, perform semi-annual maintenance. Refer to the section on 'Maintenance'.

CAUTION

Performing a trip test results in operation of the Deluge Valve. Water will flow into the sprinkler piping. Take necessary precautions to prevent damage.

13. EMERGENCY INSTRUCTIONS

WARNING

Placing a control valve or detection system out of service may eliminate the fire protection capabilities of the system. Prior to proceeding, notify all Authorities Having Jurisdiction (AHJ). Consideration should be given to employment of a fire patrol in the affected areas.

Refer to the appropriate technical data page and NFPA standards for complete care, handling, installation, and maintenance instructions. For additional product and system information, Viking data pages and installation instructions are available on the Viking Web site at www.vikinggroupinc.com.

To take system out of service

After a fire, verify that the fire is OUT and that placing the system out of service has been authorized by the appropriate Authority Having Jurisdiction.

1. Close the Water Supply Control Valve (not shown).

NOTE: Sprinkler systems that have been subjected to a fire must be returned to service as soon as possible. The entire system must be inspected for damage, and repaired or replaced as necessary.

2. Open the system main drain.
3. Shut off the air supply (optional).
4. Replace any release devices, sprinklers and/or spray nozzles that have been damaged or have been exposed to fire conditions.
5. Perform all maintenance procedures recommended in Technical Data describing individual components of the system that have operated.
6. Return the system to service as soon as possible. Refer to section on 'Placing the System In Service'.



14. INSPECTIONS, TESTS, AND MAINTENANCE

WARNING

Any system maintenance that involves placing a control valve or detection system out of service may eliminate the fire protection capabilities of that system. Prior to proceeding, notify all Authorities Having Jurisdiction. Consideration should be given to employment of a fire patrol in the affected areas.

NOTICE

The owner is responsible for maintaining the fire protection system and devices in proper operating condition.

The system must be inspected and tested on a regular basis in accordance with NFPA 25. Refer to current Viking Technical Data describing individual components. The frequency of the inspections may vary due to contaminated water supplies, corrosive water supplies, corrosive atmospheres, as well as the condition of the air supply to the system. For minimum maintenance and inspection requirements, refer to NFPA 25. In addition, the Authority Having Jurisdiction may have additional maintenance, testing, and inspection requirements that must be followed.

INSPECTION

Weekly - Viking recommends a weekly visual inspection; check the following items.

- Verify that the main water supply control valve is open and that all other valves are in their normal operating position and appropriately secured.
- Check for signs of mechanical damage, leakage, and/or corrosive activity. If detected, perform maintenance as required. If necessary, replace the device.
- Verify that the valve and trim are adequately heated and protected from freezing and physical damage.

Periodic System Tests

A. Quarterly Water Flow Alarm Test

1. Notify the Authority Having Jurisdiction and those in the area affected by the test.
2. To test the local electric alarm (if provided) and/or mechanical water motor alarm (if provided), OPEN the alarm test valve in the Deluge Valve trim.
 - a. Electric alarm pressure switches (if provided) should activate.
 - b. Electric local alarms should be audible.
 - c. The local water motor gong should be audible.
 - d. If equipped with remote station alarm signaling devices, verify that alarm signals were received.
3. When testing is complete, CLOSE the Alarm Test Valve.
4. Verify the following:
 - a. All local alarms stop sounding and alarm panels (if provided) reset.
 - b. All remote station alarms reset.
 - c. Supply piping to water motor alarm properly drains.
5. Verify that the Alarm Test Valve is CLOSED.
6. Verify that the outlet chamber is free of water. No water should flow from the alarm drain line.
7. Notify the Authority Having Jurisdiction and those in the affected area that testing is complete.

B. Quarterly Main Drain Test

1. Notify the Authority Having Jurisdiction and those in the area affected by the test.
2. Record pressure reading from the Water Supply Pressure Gauge.
3. Verify that the outlet chamber of the Deluge Valve is free of water. No water should flow from the alarm drain line.
4. Fully close the Isolation Valve above the Riser Check Valve (not shown) to prevent water from entering the system.
5. Trip the system.
6. When a full flow is developed from the Flow Test Valve, record the residual pressure from the Water Supply Pressure Gauge.
7. When the test is complete, SLOWLY CLOSE the System Main Water Supply Valve.
8. Compare test results with previous flow information. If deterioration of the water supply is detected, take appropriate steps to restore adequate water supply.
9. Verify:
 - a. Normal water supply pressure has been restored to the inlet chamber, the priming chamber, and the release system. The pressure on the priming chamber water pressure gauge should equal the system water supply pressure.
 - b. All alarm devices and valves are secured in normal operating position.
10. Notify the Authority Having Jurisdiction that the test is complete. Record and/or provide notification of test results as required by the Authority Having Jurisdiction.



FSX-A Double Interlock Preaction Electric / Pneu-Lectric Release



The Viking Corporation (Far East) Pte. Ltd. | 69 Tuas View Square Westlink Techpark, Singapore 637621

ASIA PACIFIC ONLY

14. INSPECTIONS, TESTS, AND MAINTENANCE

C. Annual Trip Test

CAUTION

Any system maintenance that involves placing a control valve or detection system out of service may eliminate the fire protection capabilities of that system. Prior to proceeding, notify all Authorities Having Jurisdiction. Consideration should be given to employment of a fire patrol in the affected areas.

1. Notify the Authority Having Jurisdiction and those in the area affected by the test.
2. Fully open the Flow Test Valve to flush away any accumulation of foreign material.
3. Close the Flow Test Valve.
4. Trip the system by operating a detector. Allow a full flow to pass through the Deluge Valve. Water flow alarms should operate.
5. When test is complete:
 - a. Close the Main Water Supply Control Valve.
 - b. Open all system main drains. Allow the system to drain completely.
6. Perform semi-annual maintenance. Refer to section 'Semi-Annual Maintenance'.
7. Place the system in service. Refer to section: 'Placing the System in Service'.
8. Notify the Authority Having Jurisdiction that the test is complete. Record and/or provide notification of test results as required by the Authority Having Jurisdiction.

D. Quarterly "Low Air" Pressure Alarm Test

WARNING

Do not operate the electric detection system during this test.

1. Notify the Authority Having Jurisdiction and those in the area affected by the test.
2. Close the main water supply valve.

NOTE: Closing the main water supply valve prevents operation of the deluge valve during the test.
3. Fully open the sprinkler system's test connection.
4. Verify that the low air alarms operate within an acceptable time period and continue without interruption.
5. Close the test connection.
6. Establish recommended pneumatic supervisory pressure to be maintained. Refer to section Important Settings.
7. Reset the system release control panel to stop the alarms.
8. Return the system to service. Refer to section on 'Placing the System in Service'.

MAINTENANCE

After Each Operation

1. Sprinkler systems that have been subjected to a fire must be returned to service as soon as possible. The entire system must be inspected for damage, and repaired or replaced as necessary.
2. Deluge Valves and trim that have been subjected to brackish water, salt water, foam/water solution, or any other corrosive water supply, should be flushed with good quality fresh water before being returned to service.
3. Perform semi-annual maintenance after every operation.

Semi-Annually

1. Remove the system from service.
2. Close the Main Water Supply Control Valve.
3. Relieve pressure in the priming chamber by opening the Emergency Release.
4. Inspect all trim for signs of corrosion and/or blockage. Clean and/or replace as required.
5. Clean and/or replace all strainer screens.
6. Refer to section Placing the System in Service.

Every Fifth Year

1. Internal inspection of Deluge Valves is recommended every five years unless inspections and tests indicate more frequent internal inspections are required. Refer to the Model FSX-A Valve Technical Data Page.
2. Internal inspection of strainers, and restricted orifices is recommended every five years unless inspections and tests indicate more frequent internal inspections are required.
3. Record and provide notification of inspection results as required by the Authority Having Jurisdiction.