



## TECHNICAL DATA

### IN-LINE BALANCED PRESSURE PROPORTIONER MODEL VLF

The Viking Corporation, 210 N Industrial Park Drive, Hastings MI 49058

Telephone: 269-945-9501 Technical Services: 877-384-5464 Fax: 269-818-1680 Email: techsvcs@vikingcorp.com

Visit the Viking website for the latest edition of this technical data page.

## 1. GENERAL DESCRIPTION

The In-Line Balanced Pressure (ILBP) Proportioner is a foam proportioning device which is used to balance the higher foam concentrate pressure to the lower system water pressure on Pilot Pressure Regulating Systems or Foam Pump Proportioning Systems. The ILBP is particularly useful in providing accurate proportioning at multiple riser locations that are situated remotely from the central foam concentrate storage tank.

Different sizes of ILBP can be installed on the same foam concentrate supply system to ensure the most appropriate size and demand combination is used. The ILBP is tested and approved to work at different pressure and flow rates and will automatically adjust to give accurate proportioning across its working range.

This Technical Data is intended for trained experts.

For further information, please contact the appropriate sales office in **Section 5 Availability** or refer to the technical documentation.

The contents of this publication are subject to modifications without notice.



## 2. LISTINGS AND APPROVALS

The ILBP is FM Approved and UL Listed as part of a fire extinguishing system combining designated foam concentrates, bladder tanks and discharge devices.

FM Approved and UL Listed system components can be found at [www.approvalguide.com](http://www.approvalguide.com) and <https://iq.ulprospector.com>



FM Approved – Low Expansion Foam Systems (FM5130)



UL Listed – Guide GHXV.EX5002 (UL162)

“SFFF compatible” refers to this product as being part of a SFFF Foam system that has been tested to recognized standards. Not all configurations are available. Please consult technical data and/or the Approval/Listing for usage requirements.



NOTE: Other international approval certificates may be available upon request.

## 3. TECHNICAL DATA

### 3.1 Construction Features

- Available in 3” (DN80), 4” (DN100), 6” (DN150), 8” (DN200)
- Brass construction or Nickel Aluminium Bronze construction for superior corrosion protection
- Suitable for Horizontal or Vertical Installation
- Direction of flow indicator on body
- For use with Fresh or Salt Water
- Identification tag plate



## TECHNICAL DATA

### IN-LINE BALANCED PRESSURE PROPORTIONER MODEL VLF

The Viking Corporation, 210 N Industrial Park Drive, Hastings MI 49058  
 Telephone: 269-945-9501 Technical Services: 877-384-5464 Fax: 269-818-1680 Email: techsvcs@vikingcorp.com  
 Visit the Viking website for the latest edition of this technical data page.

### 3.2 Standard Materials

Table 3.2.1 - Standard Materials	
Nickel Aluminum Bronze Version	
Body & Nozzle	Nickel Aluminum Bronze UNS C95800 — ASTM B148
Orifice	UNS-C36000 or C46400 or C95800
Fittings	Stainless Steel
Spool Assembly	See <b>Table 6.2.2</b>
Brass Version	
Body & Nozzle	Cast Brass UNS C84400 — ASTM B584
Orifice	UNS-C36000
Fittings	Stainless Steel
Spool Assembly	See <b>Table 6.2.2</b>
<i>See notes in Table 3.4.1 for ordering information</i>	

### 3.3 Standard Design Specifications

Table 3.3.1 - Standard Design Specifications	
All Versions	
Foam concentrate inlet pressure must be minimum 15 PSI higher than water inlet pressure and maximum 50 PSI higher at concentrate controller.	
Design pressure	250 PSI / 17.2 bar (1.7MPa)
Design temperature range	14 °F to 120 °F (-10 °C to 49 °C)*
Operating temperature range	35 °F to 120 °F (1.7 °C to 49 °C)
Minimum operating inlet pressure	30 PSI / 2.1 bar (0.2MPa)
Maximum operating Inlet pressure	150 PSI / 10.3 bar (1.03MPa)
Proportioning range	Refer to <b>Table 3.4.1</b>
Foam inlet pressure	Minimum 15 PSI above system water supply pressure
Maximum static pressure	250 PSI / 17.2 bar (1.7MPa)
*Riser must be installed in an area maintained at or above 40 °F (4.4 °C)	



# TECHNICAL DATA

## IN-LINE BALANCED PRESSURE PROPORTIONER MODEL VLF

The Viking Corporation, 210 N Industrial Park Drive, Hastings MI 49058  
 Telephone: 269-945-9501 Technical Services: 877-384-5464 Fax: 269-818-1680 Email: techsvcs@vikingcorp.com  
 Visit the Viking website for the latest edition of this technical data page.

### 3.4 Ordering Information

Table 3.4.1 - Ordering information<sup>6</sup>

Connection		Foam Type <sup>5</sup>	Part Number		Orifice		FM Approved				UL Listed			
Body Grooved	Foam Inlet Grooved		Nickel Aluminium Bronze <sup>2,4</sup>	Brass <sup>3</sup>	Inches (mm)		Minimum Flow Rate <sup>1</sup>		Maximum Flow Rate <sup>1</sup>		Minimum Flow Rate		Maximum Flow Rate	
					In	mm	GPM	L/min	GPM	L/min	GPM	L/min	GPM	L/min
3" (88.9mm)	1.5" (48.3 mm)	3% XMAX	VLF089JAN	F20316N	0.362	9.19	--	--	--	--	150	568	750	2839
		Viking USP, 3%	VLF089JAL	F20316L	0.370	9.40	180	681	760	2877	--	--	--	--
4" (114.3mm)	2" (60.3 mm)	3% XMAX	VLF114JAN	F20317N	0.485	12.32	--	--	--	--	287	1507	1244	4709
		Viking USP, 3%	VLF114JAL	F20317L	0.488	12.40	455	1722	1275	4826	420	1590	1515	5735
		Viking ARK, 3%	VLF114JP	F20317P	0.488	12.40	523	1980	1273	4819	--	--	--	--
6" (165.1mm)	2" (60.3 mm)	3% XMAX	VLF165JAN	--	0.700	17.78	--	--	--	--	742	2809	2428	9191
		Viking USP, 3%	VLF165JAL	--	0.737	18.72	1240	4694	2640	9993	1512	5724	2740	10372
		Viking ARK, 3%	VLF165JP	--	0.700	17.78	1050	3975	2315	8763	--	--	--	--
6" (168.3mm)	2" (60.3 mm)	3% XMAX	VLF168JAN	F20184N	0.700	17.78	--	--	--	--	742	2809	2428	9191
		Viking USP, 3%	VLF168JAL	F20184L	0.737	18.72	1240	4694	2640	9993	1512	5724	2740	10372
		Viking ARK, 3%	VLF168JP	F20184P	0.737	18.72	1050	3975	2315	8763	--	--	--	--
8" (219.1mm)	2" (60.3 mm)	3% XMAX	VLF2196JAN	--	0.975	24.77	--	--	--	--	1953	7393	4459	16879
		Viking USP, 3%	VLF2196JAL	--	0.952	24.18	1650	6246	4250	16088	2330	8820	4130	15634
8" (219.1mm)	2" (60.3 mm)	3% XMAX	VLF2193JAN	F20185N	0.975	24.77	--	--	--	--	1953	7393	4459	16879
		Viking USP, 3%	VLF2193JAL	F20185L	0.952	24.18	1650	6246	4250	16088	2330	8820	4130	15634

#### NOTES:

<sup>1</sup> Please refer to graphs in section 7.2 for specific flow rate parameters.

<sup>2</sup> Nickel Aluminium Bronze (NAB) - Standard Offering in Viking EMEA & APAC Territories. Brass available on request with longer delivery.

<sup>3</sup> Brass - Standard Offering in Viking Americas Territories. Nickel Aluminium Bronze available on request with longer delivery.

<sup>4</sup> NAB 219mm with 73mm foam inlet are non standard and could be subject to additional lead time and price.

<sup>5</sup> All foam types comply with the requirements of the EPA 2010/2015 PFOA Stewardship Program.

<sup>6</sup> A seal kit for the spool valve is available to purchase separately. See section 13.



## TECHNICAL DATA

### IN-LINE BALANCED PRESSURE PROPORTIONER MODEL VLF

The Viking Corporation, 210 N Industrial Park Drive, Hastings MI 49058

Telephone: 269-945-9501 Technical Services: 877-384-5464 Fax: 269-818-1680 Email: [techsvcs@vikingcorp.com](mailto:techsvcs@vikingcorp.com)

Visit the Viking website for the latest edition of this technical data page.

#### 4. SCOPE OF DELIVERY

Ensure that all components are complete and in good condition.

The ILBP is supplied boxed, with a data plate and an integral sized orifice disc specific to its approved/listed concentrate.

The ILBP comes part assembled in the EMEA and APAC ordering territories as detailed in Section 8 and Figure 8.1. In the Americas ordering territory, the ILBP is supplied totally pre-assembled as detailed in Section 6.2. The ILBP is supplied with these main components:

- Balanced spool type balancing valve
- Brass swing check valve
- Duplex gauge which indicates both water pressure (black needle) and foam pressure (red needle)
- Flexible braided sensing lines
- Interconnecting brass nipples as indicated on the detailed drawings

#### 5. AVAILABILITY

The product is available directly from Viking and official distributors only.

##### Americas:

The Viking Corporation

5150 Beltway SE

Caledonia, MI 49316

Tel.: (800) 968-9501

Fax: 269-818-1680

Technical Services: 1-877-384-5464

[techsvcs@vikingcorp.com](mailto:techsvcs@vikingcorp.com)

#### 6. PRODUCT VARIANTS

##### 6.1 Options

- Suitable for Viking Foam Concentrate: 3% XMAX
- Nickel Aluminum Bronze UNS C95800 or Brass UNS C84400 (see table 3.4.1)
- Pre-Assembled with Bladder Tank and water/foam pipe work



# TECHNICAL DATA

## IN-LINE BALANCED PRESSURE PROPORTIONER MODEL VLF

The Viking Corporation, 210 N Industrial Park Drive, Hastings MI 49058

Telephone: 269-945-9501 Technical Services: 877-384-5464 Fax: 269-818-1680 Email: techsvcs@vikingcorp.com

Visit the Viking website for the latest edition of this technical data page.

### 6.2 Dimensions and Equivalent Length

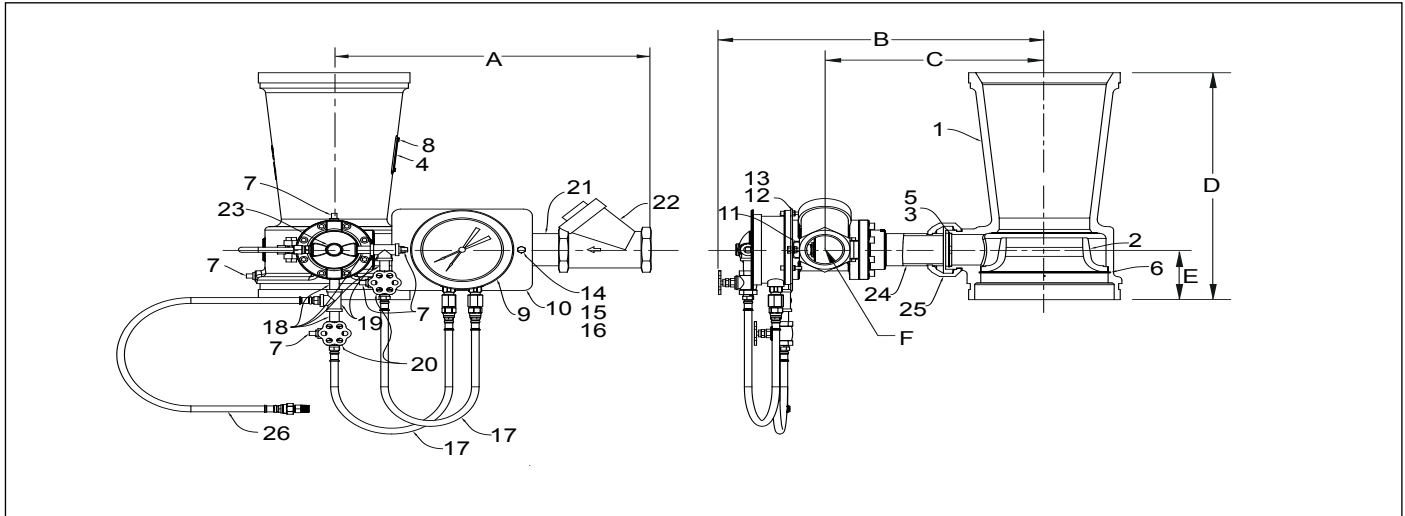

Table 6.2.2 - ILBP Assembly Components

Item	Description	Qty	Replacement Part	Item	Description	Qty	Replacement Part
1	Ratio Controller	1	N/A	14	Bolt	2	N/A
2	Nozzle	1	N/A	15	Lock Washer	2	N/A
3	Orifice Plate	1	N/A	16	Nut	2	N/A
4	Data Plate	1	N/A	17	Sensing Line Assembly	2	F09565
5	Retaining Ring	1	N/A	18	Nipple	4	N/A
6	Retaining Ring	1	N/A	19	Tee	2	N/A
7	1/4" Plug	5	14BRPLUG	20	Side Outlet Valve	2	03952A
8	Rivet	2	N/A	21	Nipple	1	N/A
9	Gauge	1	F09646	22	Swing Check Valve (NPT)	1	F09664 (1-1/2") F09665 (2")
10	Mounting Plate	1	N/A	23	Spool Valve	1	N/A
11	Pipe Clamp	1	N/A	24	Nipple	1	N/A
12	Screw	3	N/A	25	Grooved Coupling	1	N/A
13	Nut	3	N/A	26	Sensing Line Assembly	1	F09615

Table 6.2.3 - Equivalent Length, Weight and Dimension Data

Nominal Size (Grooved)	Equivalent Length (friction loss)*		Approximate Weight				Approximate Dimensions											
			NAB Version		Brass Version		A		B		C		D		E		Foam Inlet (F)	
	Feet	Metre	LBS	KGs	LBS	KGs	Inch	mm	Inch	mm	Inch	mm	Inch	mm	Inch	mm	Inch	mm
3" (DN80)	31	9.45	41.1	18.6	43.5	19.7	17-5/16	440	16	406	9-15/16	252	9-1/4	235	2-15/16	75	1-1/2	40
4" (DN100)	37	11.28	47.5	21.5	58.5	26.5	18	458	16-3/8	415	10-2/8	261	11	279	3-5/16	84	2	50
6" (DN150)	88	26.82	64.2	29.1	70.5	32.0	18	458	17-7/16	442	11-3/8	289	15	381	3-5/16	84	2	50
8" (DN200)	114	34.75	85.7	38.8	96.5	43.8	18	458	18-7/16	468	12-3/8	314	16-3/4	425	3-11/16	94	2	50

\* Expressed in equivalent length of schedule 40 pipe based on Hazen & Williams C=120



# TECHNICAL DATA

## IN-LINE BALANCED PRESSURE PROPORTIONER MODEL VLF

The Viking Corporation, 210 N Industrial Park Drive, Hastings MI 49058  
 Telephone: 269-945-9501 Technical Services: 877-384-5464 Fax: 269-818-1680 Email: techsvcs@vikingcorp.com  
 Visit the Viking website for the latest edition of this technical data page.

### 7. PERFORMANCE DATA

#### 7.1 Friction Loss vs Foam Solution Flow

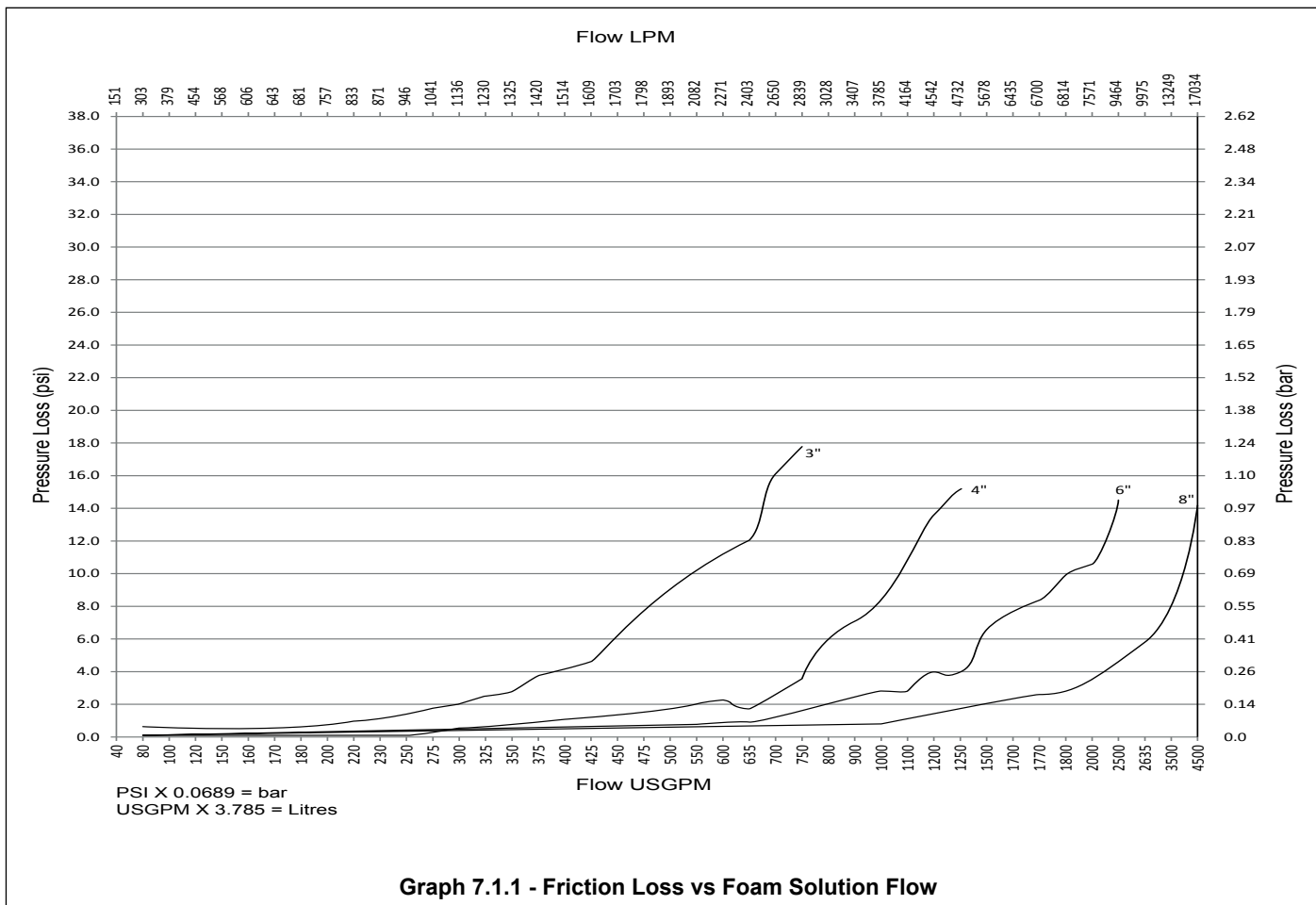



# TECHNICAL DATA

## IN-LINE BALANCED PRESSURE PROPORTIONER MODEL VLF

The Viking Corporation, 210 N Industrial Park Drive, Hastings MI 49058  
 Telephone: 269-945-9501 Technical Services: 877-384-5464 Fax: 269-818-1680 Email: techsvcs@vikingcorp.com  
 Visit the Viking website for the latest edition of this technical data page.

### 7.2 Inlet Pressure vs Foam Solution Flow

The ILBP must be used within the shaded flow and pressure conditions.

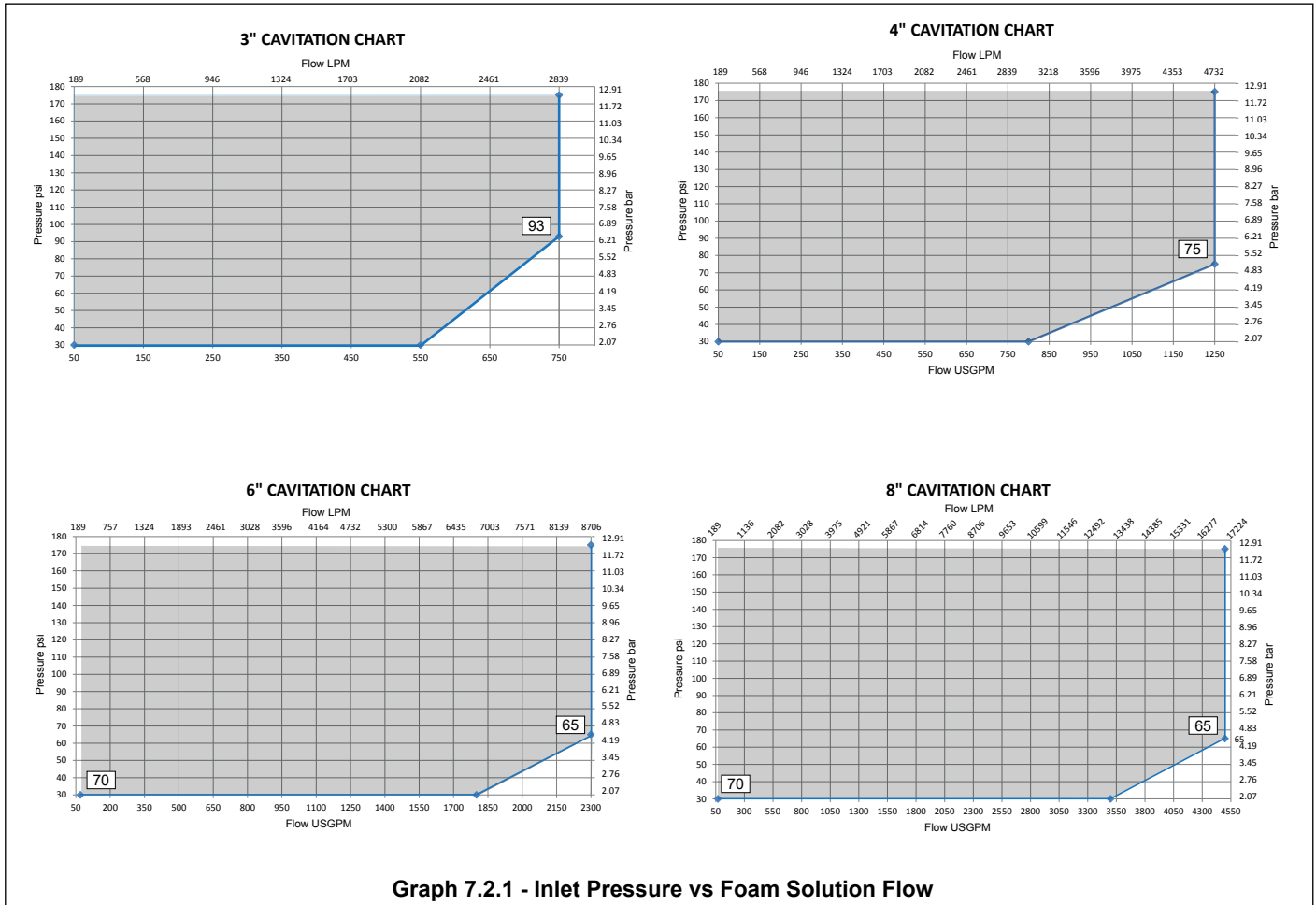



## TECHNICAL DATA

### IN-LINE BALANCED PRESSURE PROPORTIONER MODEL VLF

The Viking Corporation, 210 N Industrial Park Drive, Hastings MI 49058

Telephone: 269-945-9501 Technical Services: 877-384-5464 Fax: 269-818-1680 Email: techsvcs@vikingcorp.com

Visit the Viking website for the latest edition of this technical data page.

## 8. INSTALLATION

Refer to appropriate Installation Standards (i.e. NFPA, VdS, LPCB, etc.) and / or applicable FM Global Property Loss Prevention Data Sheets such as 4-12, Foam-Water Sprinkler Systems. Do not alter the piping without consulting a system design representative. Before installing a ratio controller, check the system design drawing to ensure the controller location does not create excessive head pressure or frictional losses.

(Refer to Section 6.2 for identification of ILBP components.)

**NOTE: On a Viking Low Flow Bladder Tank System, the water supply flowing pressure at the inlet of the ratio controller and the discharge outlet of the Viking pressure regulating valve must be set at a minimum of 15 PSI lower than the system flowing pressure at the inlet to the Viking pressure regulating valve. (Refer to the website for instructions on how to adjust the outlet pressure on the Viking Pilot Operated Pressure Control Valve, Model A-2 or B-1, under a flowing condition.)**

For Foam Pump Systems, the foam concentrate pressure must be a minimum of 15 PSI higher than the system water pressure at the inlet of the ratio controller.

The Viking ILBP is a partially pre-assembled proportioning device, complete with a duplex water and foam pressure gauge, spool valve, concentrate controller, check valve, sensing lines and associated brass piping. It is an integral part of the Viking Low Flow Foam System, and must be installed in accordance with the following instructions.

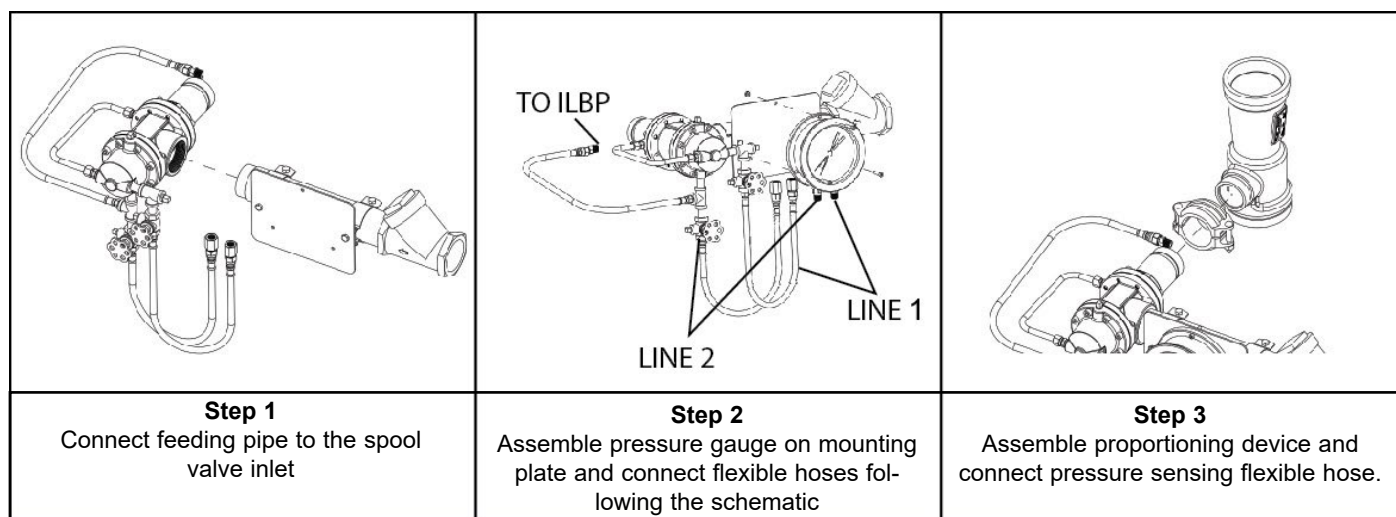

**Figure 8.1 - Assembling the Viking ILBP  
(EMEA and APAC ordering territories only.  
Viking Americas product is shipped fully assembled)**

The ratio controller section of the ILBP is installed in the riser, on the system side of the Viking Pressure Regulating Valve assembly (on Viking Low Flow Foam Bladder Tank Systems).

The ILBP unit is shipped with the foam pressure sensing line already installed at the end of the spool valve. The water sensing line must be field installed following the schematics above. The foam concentrate supply line from the Viking Halar® coated concentrate valve is then connected to the inlet of the swing check valve. Refer to the appropriate Viking technical data pages for instructions as to completing the system installation and testing of the Low Flow Foam System or foam pump system.

- The ILBP (ratio controller) must be installed with the arrow pointing in the direction of the water flow
- The ILBP (ratio controller) can be installed in the vertical or horizontal position
- The balancing spool valve must always lie horizontally (Fig 8.2)
- The foam concentrate supply line diameter may need to be increased above the foam inlet size ("F" Fig 6.2.1) due to friction loss in piping from the riser back to the foam source
- In Deluge and Preaction systems a removable section of pipe should be installed between the Concentrate Control Valve and ILBP foam inlet to allow the flushing of foam concentrate after system activation or testing
- A foam concentrate supply pressure gauge is recommended adjacent to foam inlet of the CCV
- If installed in a horizontal header, the check valve ("22" Fig 6.2.1) must be oriented so that the clapper is perpendicular to the floor and access hole is facing up (as shown below)
- **Straight piping equal to a minimum of five (5) pipe diameters should be installed before and after the ILBP (ratio controller) to help ensure proportioning accuracy**



## TECHNICAL DATA

### IN-LINE BALANCED PRESSURE PROPORTIONER MODEL VLF

The Viking Corporation, 210 N Industrial Park Drive, Hastings MI 49058  
 Telephone: 269-945-9501 Technical Services: 877-384-5464 Fax: 269-818-1680 Email: techsvcs@vikingcorp.com  
 Visit the Viking website for the latest edition of this technical data page.

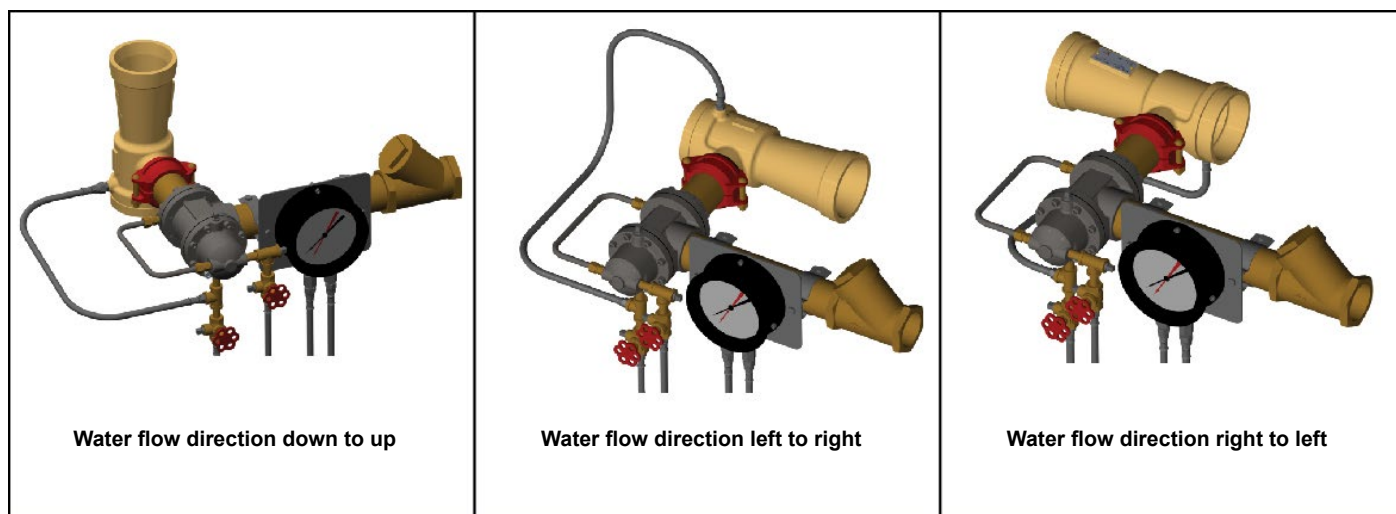

Figure 8.2 - Typical Proportioning Device Orientations

## 9. OPERATION

The system water pressure, under a water flow condition, must be at least 15 PSI lower than the foam concentrate pressure at the ratio controller (1).

- The reduction in system water pressure for a Viking Low Flow Bladder Tank System is accomplished by the use of the Viking Pilot Pressure Regulating Valve, which is also a component of the Viking Low Flow Foam System.
- For foam pump systems, the foam pressure at the ILBP must be at least 15 PSI higher than the water pressure.

Upon system actuation, water begins to flow through the piping network, including the ILBP.

The ILBP water sensing line (connected upstream of the ratio controller by installer) and foam sensing line are connected to upper and lower side of internal hydraulic piston. The piston is integrally attached to the balanced spool of the pressure balancing valve.

As the foam concentrate discharge pressure from the spool valve increases above the inlet water pressure, the spool valve closes over the discharge ports of the balancing valve until the foam pressure equals water pressure. This allows the correct balanced pressure foam concentrate to flow through the metering orifice of the ratio controller.

As the discharge foam concentrate pressure is lowered below the water supply pressure due to increase in flow and metering pressure drop caused by the venturi of the ratio controller, the piston and spool valve open to allow more flow as required. When the foam concentrate inlet pressure is equal to the water inlet pressure of the ratio controller, the proper mixture of foam solution is developed at the minimum and maximum flow rates shown for each size ILBP and foam concentrate being applied.

Due to the foam concentrate pressure being supplied at a higher pressure than the water supply, a positive injection of foam concentrate occurs. This will cause rich foam solution below the minimum flow rates shown or at the initial fire condition where a small discharge flow rate occurs where only a few sprinklers have opened. As additional sprinklers operate and flow increases, the metering pressure drop across the ratio controller's venturi matches the sized foam concentrate metering orifice thus producing the desired solution of water and foam mixture as indicated in **Table 3.4.1**.

## 10. GUARANTEE

For details of warranty, refer to Viking's current list price schedule or contact Viking directly.



## TECHNICAL DATA

### IN-LINE BALANCED PRESSURE PROPORTIONER MODEL VLF

The Viking Corporation, 210 N Industrial Park Drive, Hastings MI 49058  
 Telephone: 269-945-9501 Technical Services: 877-384-5464 Fax: 269-818-1680 Email: techsvcs@vikingcorp.com  
 Visit the Viking website for the latest edition of this technical data page.

## 11. INSPECTION, TESTS AND MAINTENANCE

Refer to respective requirements, according to the relevant standards for Inspection, Testing and Maintenance. If applicable, refer to FM Global Property Loss Prevention Datasheet 4-12 for specific test and commissioning criteria. In addition, the "Authority Having Jurisdiction" (AHJ) may have additional maintenance, testing and inspection requirements that must be followed.

### NOTICE

The owner is responsible for maintaining the fire protection system and devices in proper operating condition. The Pilot Operated Pressure Control Valve must be kept from freezing conditions and physical damage that could impair its operation.

### WARNING

Any system maintenance or testing that involves placing a control valve or detection system out of service may eliminate the fire protection of that system. Prior to proceeding, notify all Authorities Having Jurisdiction. Consideration should be given to employment of a fire patrol in the affected area.

## 12. DISPOSAL



At end of use the product described here should be disposed of via the national recycling system.

## 13. ACCESSORIES AND SPARE PARTS

Seal Kit for Spool Valve: Part No. F22821  
 See Table 6.2.2 for additional spare parts.

## 14. DECLARATION OF CONFORMITY

If required, contact the appropriate sales office in **Section 5 Availability** for further assistance.